

# ICC-ES Evaluation Report

ESR-2113

Reissued August 2025

Revised January 2026



Subject to renewal August 2027

This report also contains:

- [CA Supplement](#)

ICC-ES Evaluation Reports are not to be construed as representing aesthetics or any other attributes not specifically addressed, nor are they to be construed as an endorsement of the subject of the report or a recommendation for its use. There is no warranty by ICC Evaluation Service, LLC, express or implied, as to any finding or other matter in this report, or as to any product covered by the report.

Copyright © 2026 ICC Evaluation Service, LLC. All rights reserved.

<p><b>DIVISION: 32 00 00—</b> <b>EXTERIOR IMPROVEMENTS</b></p> <p><b>Section: 32 32 00—</b> <b>Retaining Walls</b></p> <p><b>Section: 32 32 23—</b> <b>Segmental Retaining Walls</b></p>	<p><b>REPORT HOLDER:</b> <b>KEYSTONE RETAINING WALL SYSTEMS, LLC</b></p>  <p><b>ADDITIONAL LISTEE:</b> <b>RCP BLOCK AND BRICK, INC.</b></p>	<p><b>EVALUATION SUBJECT:</b> <b>KEYSTONE RETAINING WALL SYSTEMS</b></p>	
--	--	--	---

## 1.0 EVALUATION SCOPE

**Compliance with the following codes:**

- 2024, 2021, 2018 and 2015 [International Building Code® \(IBC\)](#)
- 2024, 2021, 2018 and 2015 [International Residential Code® \(IRC\)](#)
- 2013 *Abu Dhabi International Building Code (ADIBC)*<sup>†</sup>

<sup>†</sup>The ADIBC is based on the 2009 IBC as referenced under the ADIBC.

**Properties evaluated:**

- Physical properties

## 2.0 USES

The Keystone Retaining Wall Systems (Keystone SRWs) consist of modular concrete units for the construction of conventional gravity- or geogrid-reinforced-soil retaining walls, respectively, with or without a mass of reinforced soil, stabilized by horizontal layers of geosynthetic reinforcement materials.

## 3.0 DESCRIPTION

### 3.1 Keystone Units:

Keystone concrete units are available in four configurations: Standard III, Compac III, Compac II, Country Manor / Stonegate. See [Figure 1](#) for dimensions and nominal weights. Standard III, Compac III, Compac II units and corresponding cap units have either a straight or three-plane split face. Country Manor / Stonegate units have a straight face. Cap units are half-height units without pin holes in the top surface. The nominal unit weights, noted in [Figure 1](#), are to be used in design.

Standard III, Compac III and Compac II units have four holes each for installation of two fiberglass connection pins. Country Manor / Stonegate units have six holes for installation of two fiberglass connection pins. The Small Country Manor / Stonegate Unit has three holes, for installation of one fiberglass connection pin. The underside of each unit has a slot to receive the connection pin. See [Figure 1](#) for typical unit configurations.

All units are made with normal-weight aggregates, and comply with ASTM C1372, including having a minimum 28-day compressive strength of 3,000 psi (21 MPa) [minimum of 24 MPa is required under ADIBC Appendix L, Section 5.1.1] on the net area. In areas where repeated freezing and thawing under saturated conditions occur, evidence of compliance with freeze-thaw durability requirements of ASTM C1372 must be submitted to the code official for approval prior to construction.

### 3.2 Fiberglass Pins:

Pultruded fiberglass pins provide alignment of the units during placement, positive placement of the geogrid reinforcement, and inter-unit shear strength. The connection pins are 0.5 inch (12.7 mm) in diameter and 5.25 inches (133 mm) long, and have a minimum short beam shear strength of 6,400 psi (44 MPa).

### 3.3 Unit Core Drainage Fill:

Unit core drainage fill must be  $\frac{1}{2}$  inch to  $\frac{3}{4}$  inch (13 mm to 19 mm), clean, crushed-stone material that is placed between and behind the units. The unit core fill provides additional weight to the completed wall section for stability, local drainage at the face of the structure, and a filter zone to keep the backfill soils from filtering out through the space face between units.

### 3.4 Geogrid:

The geogrid materials listed in [Tables 1](#), [2A](#) and [2B](#) are proprietary materials used to increase the height of the Keystone Wall System above the height at which the wall is stable under its self-weight as a gravity system. Geogrids are synthetic materials specifically designed for use as soil reinforcement.

## 4.0 DESIGN AND INSTALLATION

### 4.1 Design:

**4.1.1 General:** Structural calculations must be submitted to the code official for each wall system installation. The system must be designed as a conventional gravity or reinforced-soil retaining wall that depends on the weight and geometry of the concrete units and soil to resist lateral earth pressures and other lateral forces. Lateral earth pressures are determined using either Coulomb or Rankine earth pressure theory. The design must include evaluation of both external and internal stability of the structure, and include consideration of external loads such as surcharges and seismic forces, as applicable.

External stability analysis must be similar to that required for conventional retaining walls, and must consider base (lateral) sliding, overturning, bearing capacity (and excessive settlement), and overall (deep-seated) slope stability. Internal stability analysis of SRWs without geogrid-reinforced soil must consider movement between courses. Internal stability analysis of the SRWs with geogrid-reinforced soil must consider the maximum allowable reinforcement tension, pull-out resistance of reinforcement behind the active failure zone (excessive movement of geosynthetic material through the reinforced soil zone), and the connection strength of geosynthetic reinforcement material to the SRW concrete units or blocks, and movement between courses.

Minimum safety factors used in design (for external stability check) for SRWs, with and without a geogrid-reinforced soil mass, must be 1.5 for deep-seated (global) stability and 2.0 for bearing capacity. The minimum safety factors must be 1.5 for lateral sliding and 2.0 for overturning for SRWs with a geogrid-reinforced soil mass. The minimum safety factors against lateral sliding and overturning must be 1.5 (IBC Section 1807.2.3, or IRC Section R404.4, as applicable), for SRWs without a reinforced soil mass. Minimum safety factors used in design (for internal stability) must be 1.5 for peak connection strength between the geosynthetic material and SRW units, and for peak shear strength between SRW units with or without geosynthetic material. Seismic safety factors for all limit states related to SRW design may be 75 percent of the corresponding minimum allowable static safety factors.

A site-specific soils investigation report in accordance with IBC Section 1803, or IRC Section R401.4, as applicable, is required. The soils investigation report must provide a global slope stability analysis that considers the influence of site geometry, subsoil properties, groundwater conditions, and existing (or proposed) slopes above and below the proposed retaining wall. The soils investigation report must also specify the soil-reinforcement and interaction coefficients, including the coefficient of interaction for pullout and coefficient of direct sliding; and include derivation of the ultimate tensile strength of the geogrid material (according to ASTM D4595), and the applicable safety factors for the determination of the ultimate tensile strength, long-term design strength and allowable tensile strength of the geogrid. The soils investigation report must also specify safety factors for tensile rupture and pullout of the geogrid. Where the wall is assigned to Seismic Design Category (SDC) C, D, E or F, the site-specific soils report must include the information as required by IBC Section 1803.5.11. Where the wall is assigned to Seismic Design Category (SDC) D, E or F, the site-specific soils report must include the information as required by IBC Section 1803.5.12. The design of the

Keystone wall is based on accepted geotechnical principles for gravity and soil-reinforced structures. Specifics of design recommended by the manufacturer are found in the Keystone Design Manual dated February 2011.

**4.1.2 Conventional Gravity Retaining Walls:** The gravity wall system relies on the weight and geometry of the Keystone units, without the contribution of geogrids, to resist lateral earth pressures. Gravity wall design is based on standard engineering principles for modular concrete retaining walls. The maximum height of retaining walls constructed using Keystone Standard III, Compac III, Compac II and Country Manor / Stonegate units is shown in [Figure 2](#) for different soil and back slope combinations. Typical design heights are 2.5 to 3 times the depth of the unit being used. Inter-unit shear capacity equations are provided in [Table 1](#).

#### **4.1.3 Geogrid-reinforced Retaining Walls:**

**4.1.3.1 General:** The geogrid reinforced soil system relies on the weight and geometry of the Keystone units and the reinforced soil mass to act as a coherent gravity mass to resist lateral earth pressures. The design of a reinforced soil structure is specific to the Keystone unit selected, soil reinforcement strength and soil interaction, soil strength properties, and structure geometry. Inter-unit shear capacity equations are provided in [Table 1](#). Grid-to-block pullout resistance values/equations are provided in [Tables 2A](#) and [2B](#). The maximum practical height above the wall base is approximately 50 feet (15 m). [Figure 3](#) shows typical component details.

**4.1.3.2 Structural Analysis:** Structural analysis must be based on accepted engineering principles, the Keystone Design Manual dated February 2011, and the IBC. The analysis must include all items noted in Sections 4.1.1, 4.1.3.2.1 and 4.1.3.2.2 of this report, and must follow the design methodology of the Keystone Design Manual dated February 2011. All contact surfaces of the units must be maintained in compression.

##### **4.1.3.2.1 External Stability Analysis:**

1. The minimum length of the reinforced mass is 0.6 times the height of the wall (as measured from the top of the leveling pad to the top of the wall) or as required to satisfy a safety factor of 1.5 on sliding at the base, whichever is greater.
2. The minimum safety factor for overturning the reinforced mass is 2.0, considering the mass as a rigid body rotating about the toe of the wall.
3. Global stability analysis must be provided for walls with slopes below the toe of the wall, walls on soft foundations, walls that will be designed for submerged conditions, or tiered walls.
4. After completion of the internal stability analysis and geogrid layout, sliding along each respective geogrid layer must be checked, including shearing through the connection at the wall face.

##### **4.1.3.2.2 Internal Stability Analysis:**

1. Geogrid spacing must be based on local stability of the Keystone units during construction. Vertical spacing is typically limited to 2 times the depth of the unit.
2. Tension calculations for each respective layer of reinforcing must be provided. Tension is based on the earth pressure and surcharge load calculated from halfway to the layer below to halfway to the layer above. Calculated tensions must not exceed the allowable geogrid strength.
3. Connection capacity must be checked for each geogrid-to-Keystone connection (see [Tables 2A](#) and [2B](#)). The calculated connection capacity must be equal to or greater than the calculated tension for each layer.
4. A calculation check must be made on pullout of the upper layers of geogrid from the soil zone beyond the theoretical Coulomb or Rankine failure plane. The pullout capacity must be equal to or greater than the calculated tension after applying the applicable geogrid interaction and sliding coefficient adjustment factors.

#### **4.2 Installation:**

The wall system units are assembled in a running bond pattern, except for the Country Manor / Stonegate units, which are assembled in a random bond pattern. The wall system units are assembled without mortar or grout, utilizing high-strength fiberglass pins for shear connections, mechanical connections of reinforcing geogrid, if applicable, and unit alignment. The system may include horizontal layers of structural geogrid reinforcement in the backfill soil mass. Requirements for installation of the Keystone Retaining Wall System are as follows:

1. Excavate for leveling pad and reinforced fill zone.
2. Inspect excavations for adequate bearing capacity of foundation soils and observation of groundwater conditions by a qualified geotechnical engineer.

3. Install a 6-inch-thick (152 mm) leveling pad of crushed stone, compacted to 75 percent relative density as determined by ASTM D4564. (An unreinforced concrete pad in accordance with IBC Section 1809.8, may be utilized in place of the crushed stone pad.)
4. Install the first course of Keystone units, ensuring units are level from side to side and front to back. Adjacent Keystone units are placed so pin holes are approximately 12 inches (305 mm) on center.
5. Install the fiberglass pins in the units to establish the angle of wall inclination (batter). The pin placement and resulting batter for given units are as follows:
  - Standard III, Compac III and Compac II Units: Placing the pin in the rear pin holes in every course provides a minimum wall inclination of 7.1 degrees from vertical toward the backfill [1 inch (25.4 mm) minimum setback per course]. Pin placement alternating between the front and rear pin holes on vertically adjacent rows provides a wall inclination of approximately 3.6 degrees from vertical toward the backfill [ $1/2$  inch (13 mm) minimum setback per course]. The pin placement during assembly in the front pin hole provides a wall inclination of approximately 0.5 degree from vertical toward the backfill [ $1/8$  inch (3 mm) minimum setback per course].
  - Country Manor / Stonegate Units: Placing the pin in the rear pin holes in every course provides a wall inclination of approximately 9.5 degrees from vertical toward the backfill [1 inch (25.4 mm) setback per course]. Placing the pin in the middle pin hole provides a wall inclination of approximately 0.5 degree from vertical toward the backfill [ $1/8$  inch (3 mm) minimum setback per course].
6. Fill the unit cores with unit core drainage fill described in Section 3.3 of this report. The unit core drainage fill is required for all installations and must extend back a minimum of 2 feet (610 mm) from the outside or front face of the wall. See [Figure 3](#).
7. Clean the top surface of the units to remove loose aggregate.
8. At designated elevation per the design, install geogrid reinforcing. All geogrid reinforcement is installed by placing it over the fiberglass pin. Check to ensure the proper orientation of the geogrid reinforcement is used so the strong direction is perpendicular to the face. Adjacent rolls are placed side by side; no overlap is required.
9. Pull taut to remove slack from the geogrids before placing backfill. Pull the entire length taut to remove any folds or wrinkles.
10. Place and compact backfill over the geogrid reinforcing layer in appropriate lift thickness to ensure compaction.
11. Repeat placement of units, core fill, backfill, and geogrids, as shown on plans, to finished grade.
12. Backfill used in the reinforced fill mass must consist of suitable fine-grained or coarse-grained soil placed in lifts compacted to at least 90 percent of the maximum dry density as determined by ASTM D1557 (95 percent per ASTM D698). The backfill soil properties, lift thickness, and degree of compaction must be determined by the soils engineer based on site-specific conditions. In cut-wall applications, if the reinforced soil has poor drainage properties, a granular drainage layer of synthetic drainage composite should be installed to prevent buildup of hydrostatic pressures behind the reinforced soil mass. Provisions for adequate subsurface drainage must be determined by the soils engineer.
13. Stack and align units using the structural pin connection between vertically adjacent units at the design setback batter. The completed wall is built with alignment tolerances of 1.5 inches (40 mm) in 10 feet (3048 mm) in both the horizontal and vertical directions.
14. When required by the design, geogrid reinforcement is placed at the elevations specified in the design. The reinforced backfill must be placed and compacted no lower than the top unit-elevation to which geogrid placement is required.

#### 4.3 Special Inspection:

Special inspection must be provided in accordance with IBC Sections 1705.1.1, 1705.4 and 1705.6. The inspector's responsibilities include verifying the following:

1. The modular concrete unit type and dimensions.
2. Keystone unit identification compliance with ASTM C1372, including compressive strength and water absorption, as described in Section 3.1 of this report.
3. Product identification, including evaluation report number (ESR-2113).

4. Foundation preparation.
5. Keystone unit placement, including proper alignment and inclination.
6. Fiberglass pin connections, including installation locations, proper fit within the blocks, and installation sequence with respect to the geogrid placement.
7. Geosynthetic reinforcement type (manufacturer and model number), location and placement.
8. Backfill placement and compaction.
9. Drainage provisions.

## 5.0 CONDITIONS OF USE:

The Keystone Retaining Wall Systems described in this report comply with, or are suitable alternatives to what is specified in, those codes listed in Section 1.0 of this report, subject to the following conditions:

- 5.1 The systems are designed and installed in accordance with this report; the Keystone Design Manual, dated February 2011; the manufacturer's published installation instructions; and accepted engineering principles. If there is a conflict between this report and the manufacturer's published installation instructions, this report governs.
- 5.2 The Keystone Design Manual, dated February 2011, is submitted to the code official upon request.
- 5.3 The wall design calculations are submitted to, and approved by, the code official. The calculations must be prepared by a registered design professional where required by the statutes of the jurisdiction in which the project is to be constructed.
- 5.4 A site-specific soils investigation in accordance with IBC Section 1803, or IRC Section R401.4, as applicable, as noted in Section 4.1.1 of this report, must be provided for each project site.
- 5.5 In areas where repeated freezing and thawing under saturated conditions occur, evidence of compliance with freeze-thaw durability requirements of ASTM C1372 must be furnished to the code official for approval prior to construction.
- 5.6 Special inspection must be provided for backfill placement and compaction, geogrid placement (when applicable), and block installation, in accordance with Section 4.3 of this report.
- 5.7 Details in this report are limited to areas outside of groundwater. For applications where free-flowing groundwater is encountered, or where wall systems are submerged, the installation and design of systems must comply with the recommendations of the soils engineer and the appropriate sections of the NCMA Design Manual for Segmental Retaining Walls, and must be approved by the code official.
- 5.8 Project specifications for soil and water conditions have sulfate concentrations identified in ACI 318 Table 19.3.1.1 as severe (S2) or very severe (S3), must include mix designs for the concrete, masonry and grout that comply with the intent of ACI 318 Table 19.3.1.1.
- 5.9 As to the geogrid reinforcement material, this report evaluates only the connection strength of the geogrid material when attached to the concrete units. Physical properties of the geogrid material or its interaction with the soil have not been evaluated.

## 6.0 EVIDENCE SUBMITTED

Data in accordance with the [ICC-ES Acceptance Criteria for Segmental \(Modular\) Retaining Walls \(AC276\)](#), dated April 2021 (editorially revised June 2024).

## 7.0 IDENTIFICATION

- 7.1 The ICC-ES mark of conformity, electronic labeling, or the evaluation report number (ICC-ES ESR-2113) along with the name, registered trademark, or registered logo of the report holder and/or listee must be included in the product label.
- 7.2 In addition, each pallet of concrete units is identified with the manufacturer's name and address, the name of the product and the unit type. Fiberglass pins are provided with each shipment of blocks, with a letter of certification by Keystone.

7.3 The report holder’s contact information is the following:

**KEYSTONE RETAINING WALL SYSTEMS, LLC**  
**4444 WEST 78<sup>TH</sup> STREET**  
**MINNEAPOLIS, MINNESOTA 55435**  
[www.keystonewalls.com](http://www.keystonewalls.com)

7.4 The Additional Listee’s contact information is the following:

**RCP BLOCK AND BRICK, INC.**  
**8240 BROADWAY**  
**LEMON GROVE, CALIFORNIA 91945**

**TABLE 1—INTER-UNIT SHEAR RESISTANCE<sup>1</sup>**

UNIT	PEAK CONNECTION STRENGTH (pounds/linear foot)		SERVICEABILITY CONNECTION STRENGTH (pounds/linear foot)		
	Equation	Maximum	Equation	Maximum	
<b>WITHOUT GEOGRID</b>					
Compac II	$F = 1376 + 0.14 N$	1783	$F = 1263 + 0.12 N$	1618	
Country Manor / Stonegate	$F = 1536$	1536	$F = 92 + 0.81 N$	1124	
Compac III	$F = 1543 + 0.74 N$	4138	$F = 649 + 0.73 N$	3206	
Standard III	$F = 2437 + 0.53 N$	5084	$F = 1524 + 0.6 N$	4528	
<b>WITH GEOGRID</b>					
Standard III	Miragrid 3XT	$P = 1711 + 0.55 N$	4456	$P = 1464 + 0.43 N$	3614
	Miragrid 8XT	$P = 2197 + 0.45 N$	4447	$P = 1977 + 0.23 N$	3133
Compac III	Miragrid 3XT	$P = 1271 + 0.65 N$	3539	$P = 543 + 0.69 N$	2953
	Miragrid 8XT	$P = 1282 + 0.56 N$	3223	$P = 706 + 0.3N$	1591

For SI: 1 lb/linear foot = 14.6 N/m.

<sup>1</sup>The inter-unit shear resistance, F [lb/linear foot (N/m)], of the Keystone units at any depth is a function of the pin strength and superimposed normal (applied) load, N [lb/linear foot (N/m)].

TABLE 2A—GEOGRID-TO-BLOCK PULLOUT RESISTANCE EQUATIONS

GEOGRID	PEAK CONNECTION STRENGTH (lbs/ft)		SERVICEABILITY CONNECTION STRENGTH (lbs/ft)	
	Equation	Maximum	Equation	Maximum
<b>KEYSTONE COMPAC II UNIT</b>				
<b>Strata Systems</b>				
Stratagrid SG150	$P = 798 + 0.34 N$	1576	$P = 593 + 0.27 N$	1184
Stratagrid SG200	$P = 707 + 0.93 N$	1754	$P = 928 + 0.10 N$	1250
Stratagrid SG500	$P = 626 + 1.15 N$	2000	$P = 770 + 0.42 N$	1705
<b>TC Mirafi</b>				
Miragrid 2XT	$P = 800 + 0.29 N$	1452	$P = 800 + 0.29 N$	1452
Miragrid 3XT	$P = 811 + 0.36 N$	1617	$P = 571 + 0.45 N$	1593
Miragrid 5XT	$P = 1200 + 0.38 N$	2050	$P = 691 + 0.55 N$	1941
Miragrid 7XT	$P = 1173 + 0.40 N$	2222	$P = 622 + 0.47 N$	1948
Miragrid 8XT	$P = 960 + 0.84 N$	2490	$P = 691 + 0.73 N$	2280
<b>KEYSTONE COUNTRY MANOR / STONEGATE UNIT</b>				
<b>Strata Systems</b>				
Stratagrid SG150	$P = 377 + 0.47 N$	950	$P = 327 + 0.48 N$	932
Stratagrid SG200	$P = 550 + 0.43 N$	1238	$P = 311 + 0.38 N$	903
<b>Tensar</b>				
BX1200	$P = 474 + 0.42 N$	1142	$P = 494 + 0.36 N$	1045

For **SI**: 1 lb/linear ft. = 14.6 N/m.

<sup>1</sup>Where N = superimposed normal (applied) load (lb/linear foot).

TABLE 2B— GEOGRID-TO-BLOCK PULLOUT RESISTANCE VALUES

BX1202	Peak Connection Strength (lbs/ft)					Serviceability Connection Strength (lbs/ft)				
	Minimum Connection Capacity	Normal Load IP-1	Connection Capacity IP-1	Normal Load IP-2	Connection Capacity IP-2	Minimum Connection Capacity	Normal Load IP-1	Connection Capacity IP-1	Normal Load IP-2	Connection Capacity IP-2
<b>KEYSTONE COMPAC III UNIT</b>										
<b>Strata Systems</b>										
Stratagrid SG200	1070.00	2493.00	2179.96	6000.00	2179.96	412.65	2493.00	1659.42	6000.00	1659.42
Stratagrid SG550	1150.00	1700.00	2735.28	3502.00	3409.02	897.82	3502.00	1562.70	6000.00	1562.70
<b>Tencate Mirafi</b>										
Miragrid 3XT	1345.22	2500.00	2020.24	6000.00	2020.24	398.97	2500.00	1374.18	6000.00	1374.18
Miragrid 8XT	1226.00	2710.00	2919.40	6000.00	2919.40	750.46	3498.00	1659.67	6000.00	1659.67
<b>Huesker</b>										
Fortrac 35T	900.00	1500.00	1372.95	6000.00	1372.95	842.82	2493.00	892.86	6000.00	892.86
Fortrac 80T	856.00	1700.00	1798.33	3500.00	2006.59	844.00	3500.00	1524.33	6000.00	1524.33
<b>KEYSTONE STANDARD III UNIT</b>										
<b>Strata Systems</b>										
Stratagrid SG200	1823.21	3002.00	1973.18	6000.00	1973.18	889.70	3002.00	1189.87	6000.00	1189.87
Stratagrid SG550	2322.00	2000.00	4060.57	5002.00	4402.61	955.00	2000.00	1682.94	6000.00	1524.33
<b>Tencate Mirafi</b>										
Miragrid 3XT	1398.00	1100.00	2197.20	3000.00	2566.52	484.00	1200.00	1069.28	3000.00	1484.84
Miragrid 8XT	1911.00	1600.00	3161.06	5053.00	4556.16	843.00	3800.00	2614.97	6000.00	2614.97
<b>Huesker</b>										
Fortrac 35T	1082.00	1000.00	1204.78	6000.00	1204.78	636.00	1800.00	985.88	2956.00	1087.02
Fortrac 85T	1600.00	2000.00	2367.73	5022.00	2420.48	894.00	2000.00	1467.49	5022.00	1625.87

For SI: 1 lb/linear ft. = 14.6 N/m.

<sup>1</sup>Minimum Connection Capacity is the connection strength when the normal load is 0 lbs.

<sup>2</sup>IP-1 is the last point (in a linear relationship between the normal load (X-axis) and the Connection Strength (Y-axis)) before it changes its linear relationship of the normal load and connection strength.

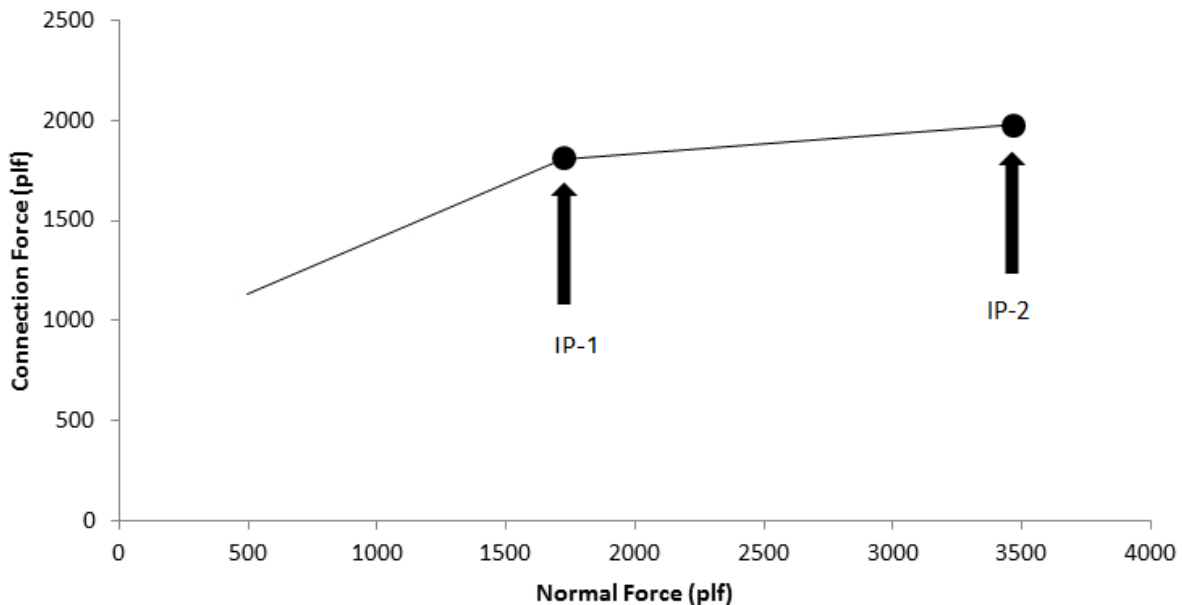

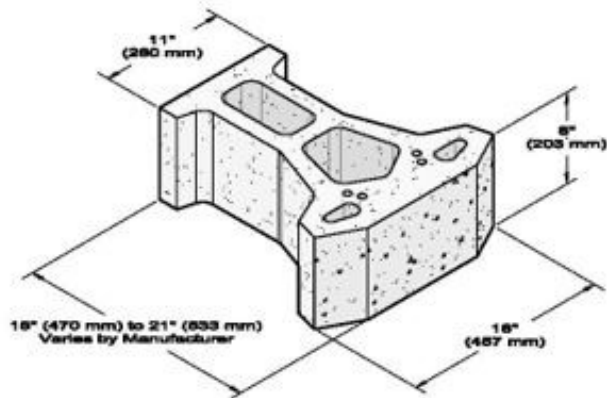

**Standard III Unit**  
92 lb. (42 kg)

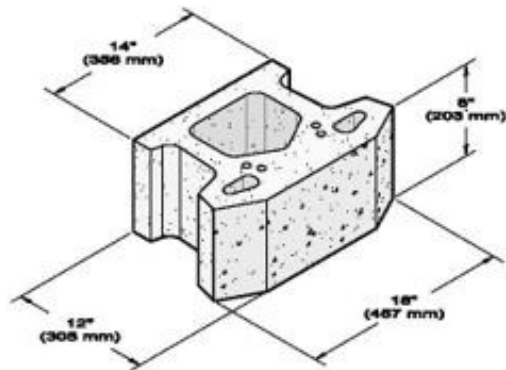

**Compac III Unit**  
72 lb. (33 kg)

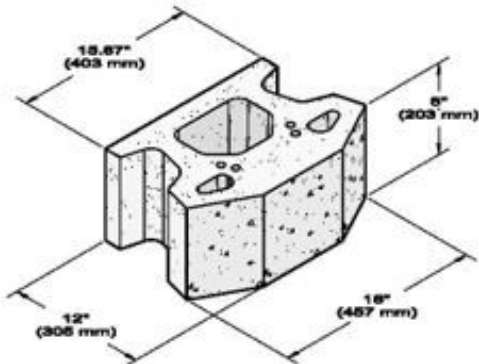

**Compac II Unit**  
82 lb. (37 kg)

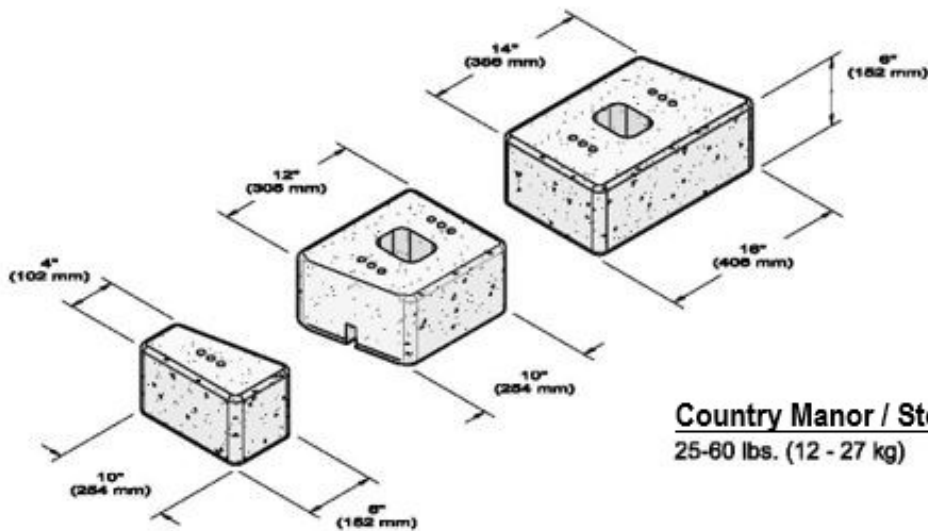

**Country Manor / Stonegate Unit**  
25-60 lbs. (12 - 27 kg)

Figure 1 - Keystone Wall Units

Three Plane Cap Unit

45 lb. (20 kg)

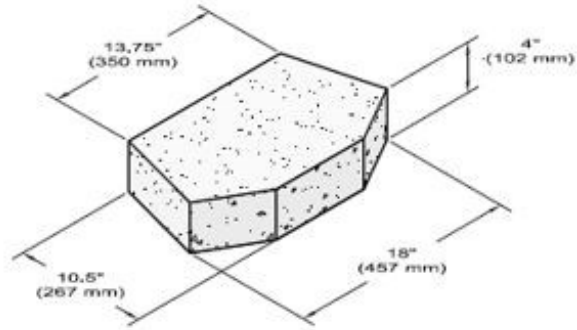

Universal Cap Unit

51 lb. (23 kg)

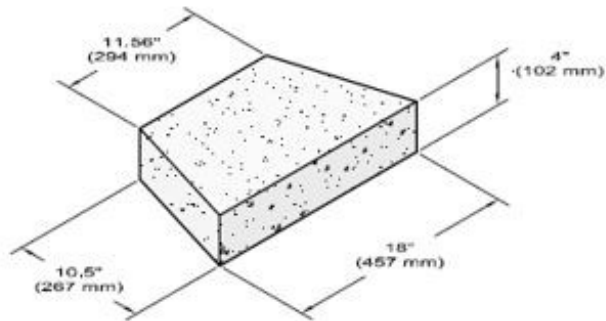

Country Manor / Stonegate Cap Unit

24 lbs. (11 kg)

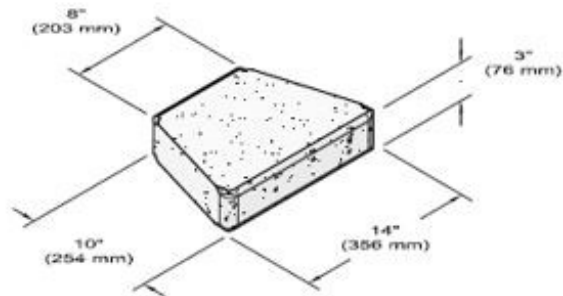
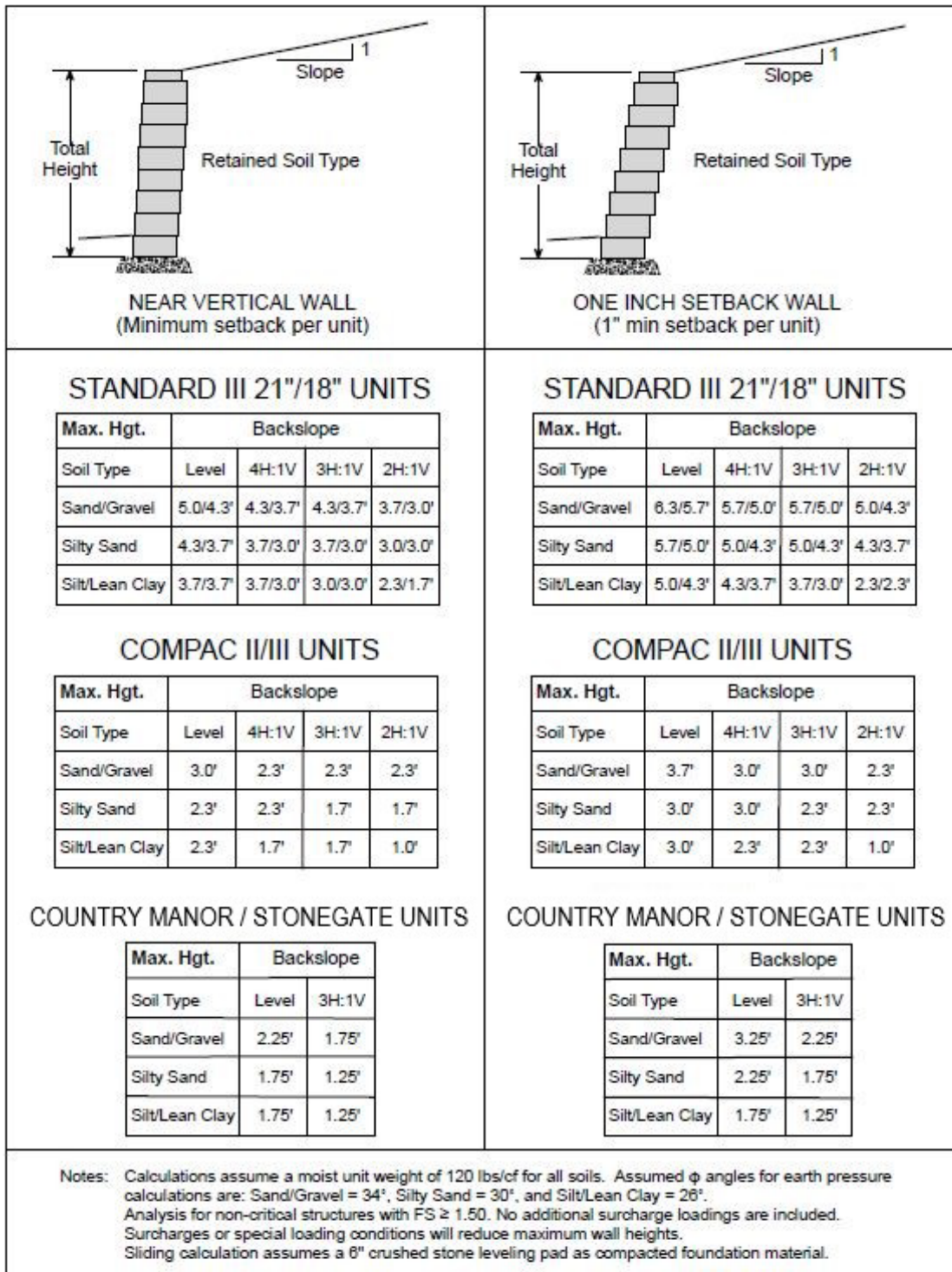

Figure 1 - Keystone Wall Units (Continued)



For SI: 1 foot = 304.8 mm

FIGURE 2 - GRAVITY WALL CHARTS

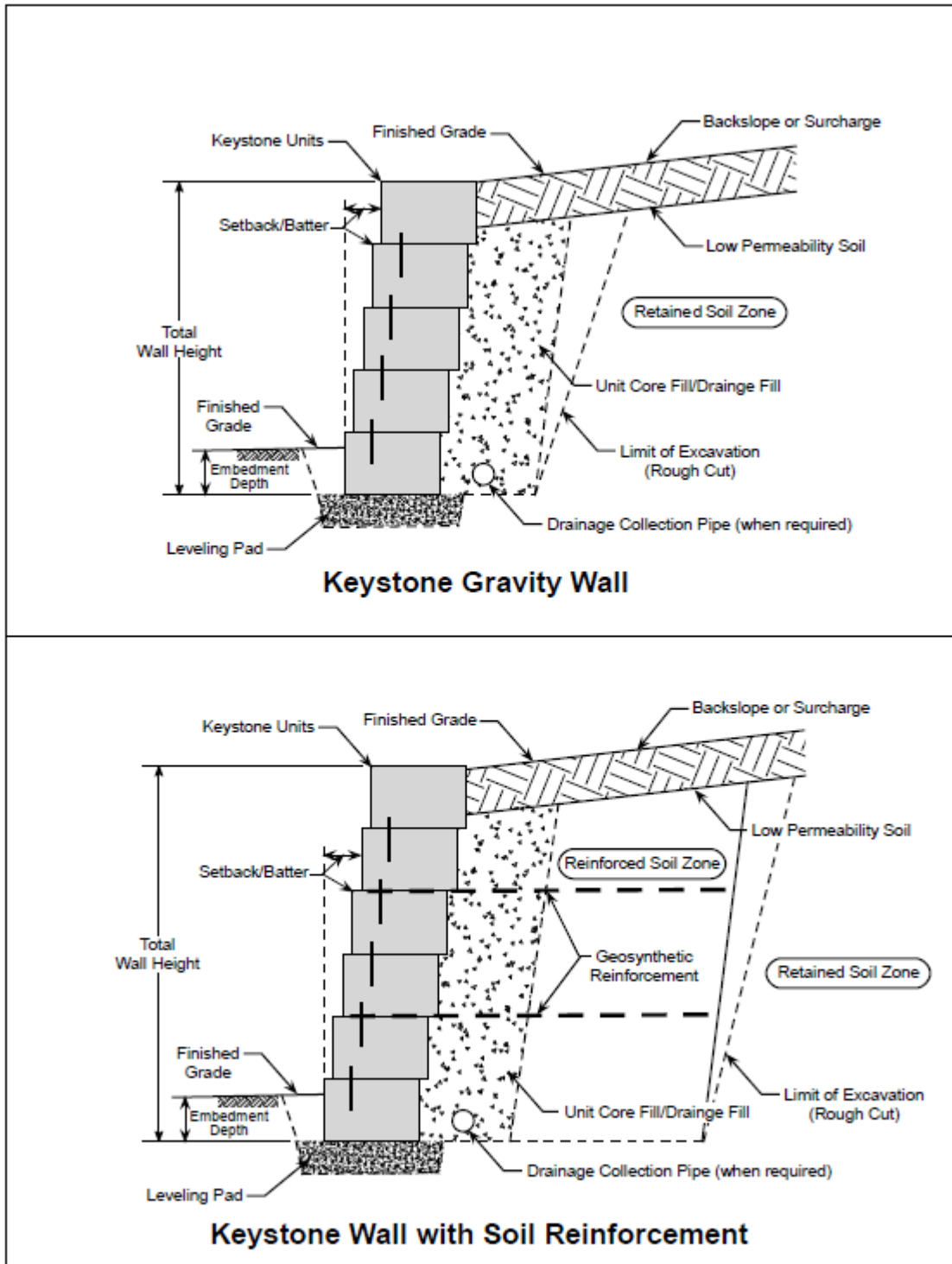

FIGURE 3 - TYPICAL WALL SECTIONS

**DIVISION: 32 00 00—EXTERIOR IMPROVEMENTS**

**Section: 32 32 00—Retaining Walls**

**Section: 32 32 23—Segmental Retaining Walls**

**REPORT HOLDER:**

**KEYSTONE RETAINING WALL SYSTEMS, LLC**

**EVALUATION SUBJECT:**

**KEYSTONE RETAINING WALL SYSTEMS**

**1.0 REPORT PURPOSE AND SCOPE**

**Purpose:**

The purpose of this evaluation report supplement is to indicate that Keystone Retaining Wall Systems, described in ICC-ES evaluation report [ESR-2113](#), have also been evaluated for compliance with the code noted below.

**Applicable code edition:**

- 2025 *California Building Code*® (CBC)

For evaluation of applicable chapters adopted by the California Office of Statewide Health Planning and Development (OSHPD) AKA: California Department of Health Care Access and Information (HCAI) and the Division of State Architect (DSA), see Sections 2.1.1 and 2.1.2 below.

- 2025 *California Residential Code*® (CRC)

**2.0 CONCLUSIONS**

**2.1 CBC:**

The Keystone Retaining Wall Systems, described in Sections 2.0 through 7.0 of the evaluation report [ESR-2113](#), comply with CBC Chapter 18, provided the design and installation are in accordance with the 2024 *International Building Code*® (IBC) provisions noted in the evaluation report and the additional requirements of the CBC Chapters 16, 17 and 18 as applicable.

**2.1.1 OSHPD:**

The applicable OSHPD Sections of the CBC are beyond the scope of this supplement.

**2.1.2 DSA:**

The applicable DSA Sections of the CBC are beyond the scope of this supplement.

**2.2 CRC:**

The Keystone Retaining Wall Systems, described in Sections 2.0 through 7.0 of the evaluation report [ESR-2113](#), comply with CRC Chapters 4, provided the design and installation are in accordance with the 2024 *International Residential Code*® (IRC) provisions noted in the evaluation report and the additional requirements of CRC Chapters 3 and 4 as applicable.

This supplement expires concurrently with the evaluation report, reissued August 2025 and revised January 2026.