



Note: Image above does not exactly match the detail within this design.

Stonegate

OUTDOOR KITCHEN • LINEAR DESIGN
INSTALLATION INSTRUCTIONS

KEYSTONE®
Country Manor

KEYSTONE OUTDOOR KITCHEN - LINEAR DESIGN

BASIC TOOLS

SAFETY		ALTERATIONS		LAYOUT		FINISHING		LEVELING		GENERAL		
												
Gloves	Safety Glasses	Stone Chisel	Mallet	Layout Stakes	Line	Caulking Gun	Concrete Adhesive	Level	Mallet	Shovel	Wheelbarrow	Hand Compactor

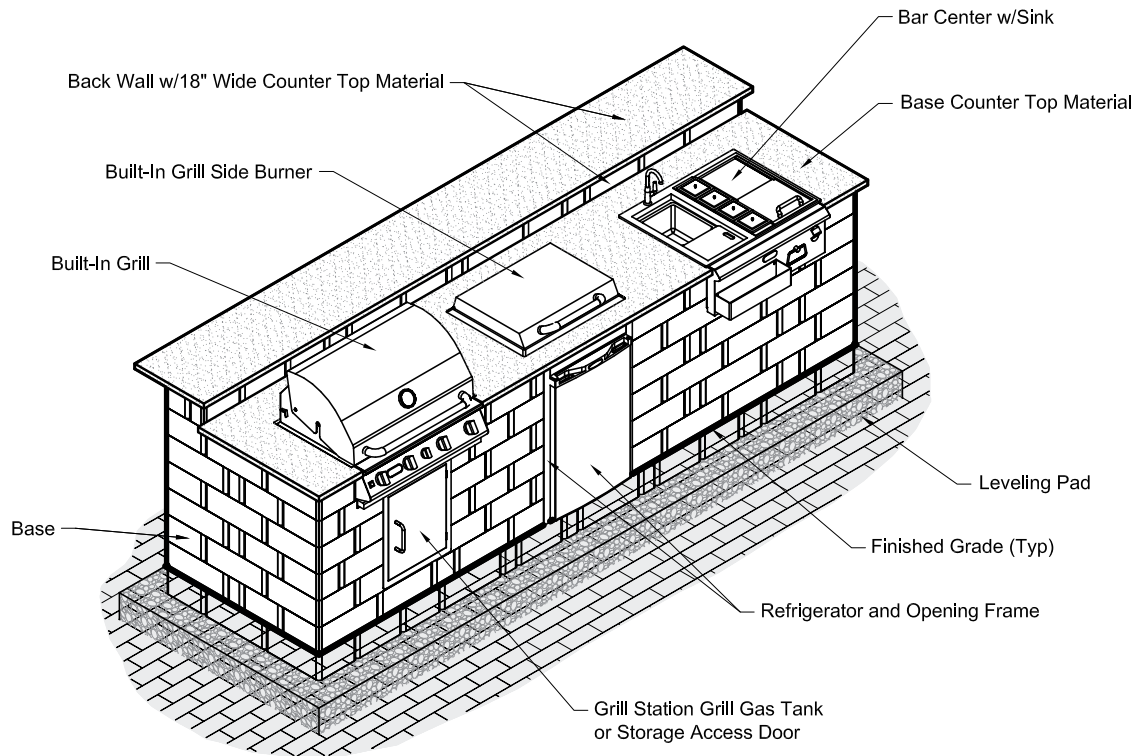

Note:
See foundation layout details sheet for further foundation information.

Grill Station Kit Front Isometric

You will need:

- 94 - 16"/14"w Country Manor/Stonegate Large units
 - 96 - 12"/10"w Country Manor/Stonegate Medium units
 - 94 - 6"/4"w Country Manor/Stonegate Small units
 - Leveling Pad Material - 27.5 cf
 - 354 ± Keystone Interlocking Pins* (50/bag)
 - 16 Tubes ± Exterior Grade Construction Adhesive
 - Built-in Grill* (30¾"w x 20" d x 9½"h rough opening)
 - Built-in Grill Double Side Burner* (22¾"w x 17½" d x 3¾"h opening)
 - Refrigerator & Frame* (20"w x 30" d x 36" h rough opening)
 - Bar Center w/sink* (29"w x 30" d x 9¾"h rough opening)
 - Access Door* (15¾" w x 22" h rough opening)
 - Upper Counter Material - 143" x 18"
 - Lower Counter Material - 143" x 31½"
- *Modify rough opening sizes in both the block units and counter top to accommodate different sized appliances, if needed.

Notes:

- All Keystone Country Manor/Stonegate units are 6" h x 10" d.
- * Keystone recommends the use of its interlocking pins when alignment allows. Use pins in conjunction with concrete adhesive to maximize stability of your structure.

KEYSTONE OUTDOOR KITCHEN - LINEAR DESIGN

Access Door/Refrigerator Opening Frame Installation Note:

- Access Door - After built-in grill is installed, adjust door w/frame vertically to desired position. Shim frame as needed. Fill top and or bottom exposed openings w/stainless steel trim as needed.
- Opening Frame - Cut top frame piece to fit opening width. Adjust frame vertically to desired position. Fill top exposed opening w/stainless steel trim as needed.

General Note:

In consideration of freeze / thaw issues during the cold weather season it is recommended that this outdoor built-in grill station element be protected from rain, snow and ice as necessary.

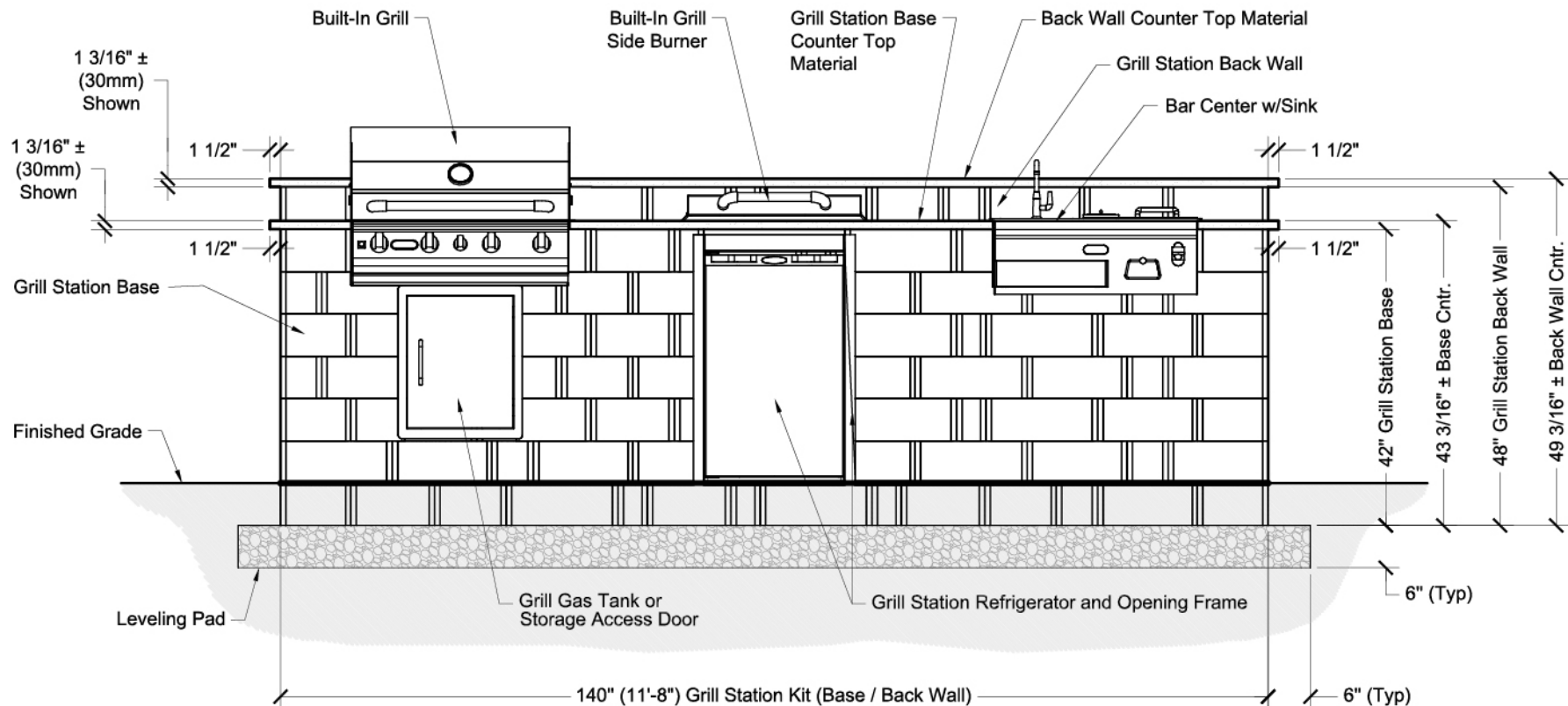

Note:

This design uses a Outdoor Stainless Steel Built-In Grill Insert w/Stainless Steel Accessories.

Grill Station Kit Front Elevation

KEYSTONE OUTDOOR KITCHEN - LINEAR DESIGN

Counter Top Support Note:

Provide under counter support as needed depending on the over hang of the counter and the type of counter top material used.

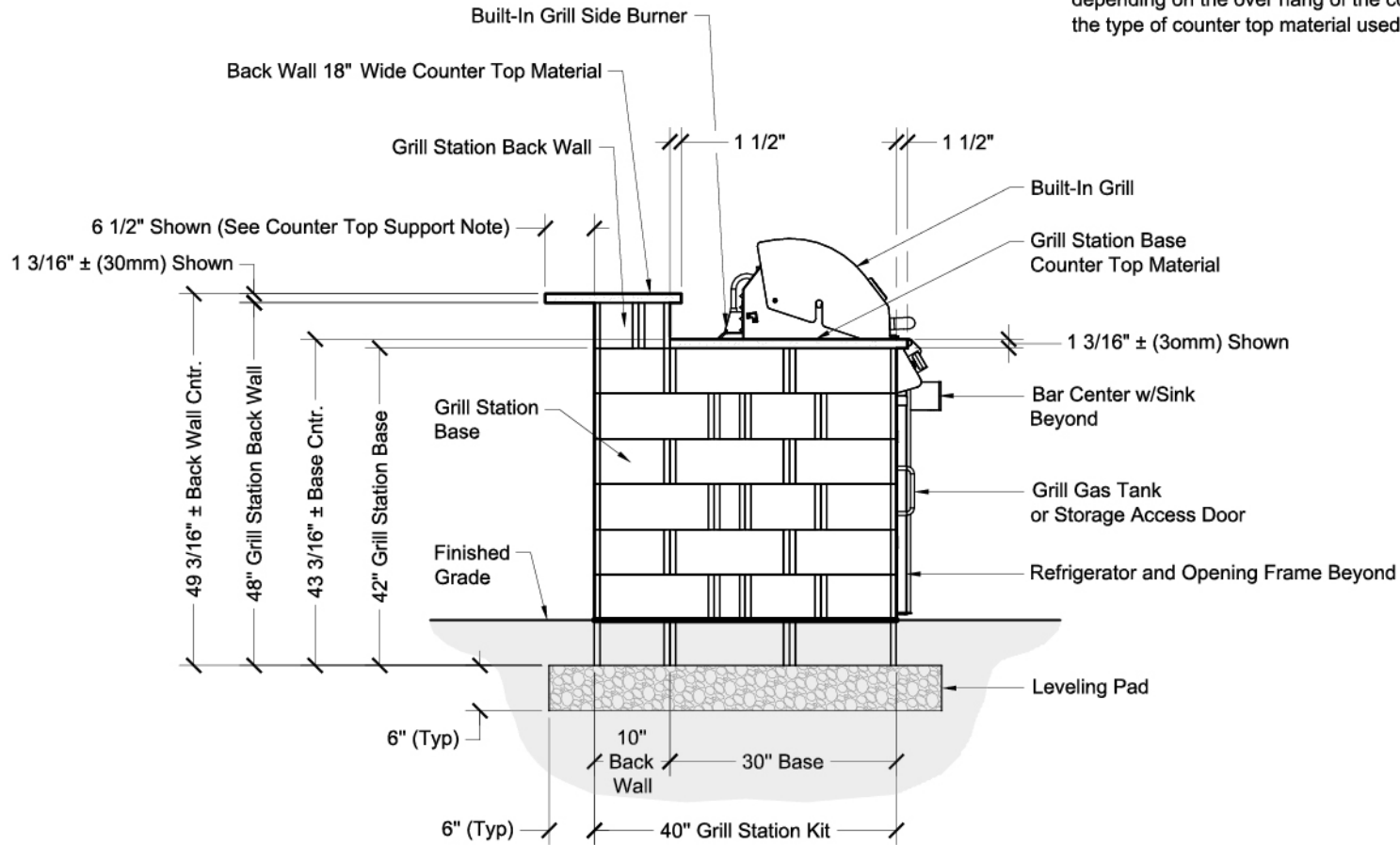

Note:

This design uses a Outdoor Stainless Steel Built-In Grill Insert w/Stainless Steel Accessories.

Grill Station Kit Side Elevation

KEYSTONE OUTDOOR KITCHEN - LINEAR DESIGN

Note:

See foundation layout details sheet for further foundation information.

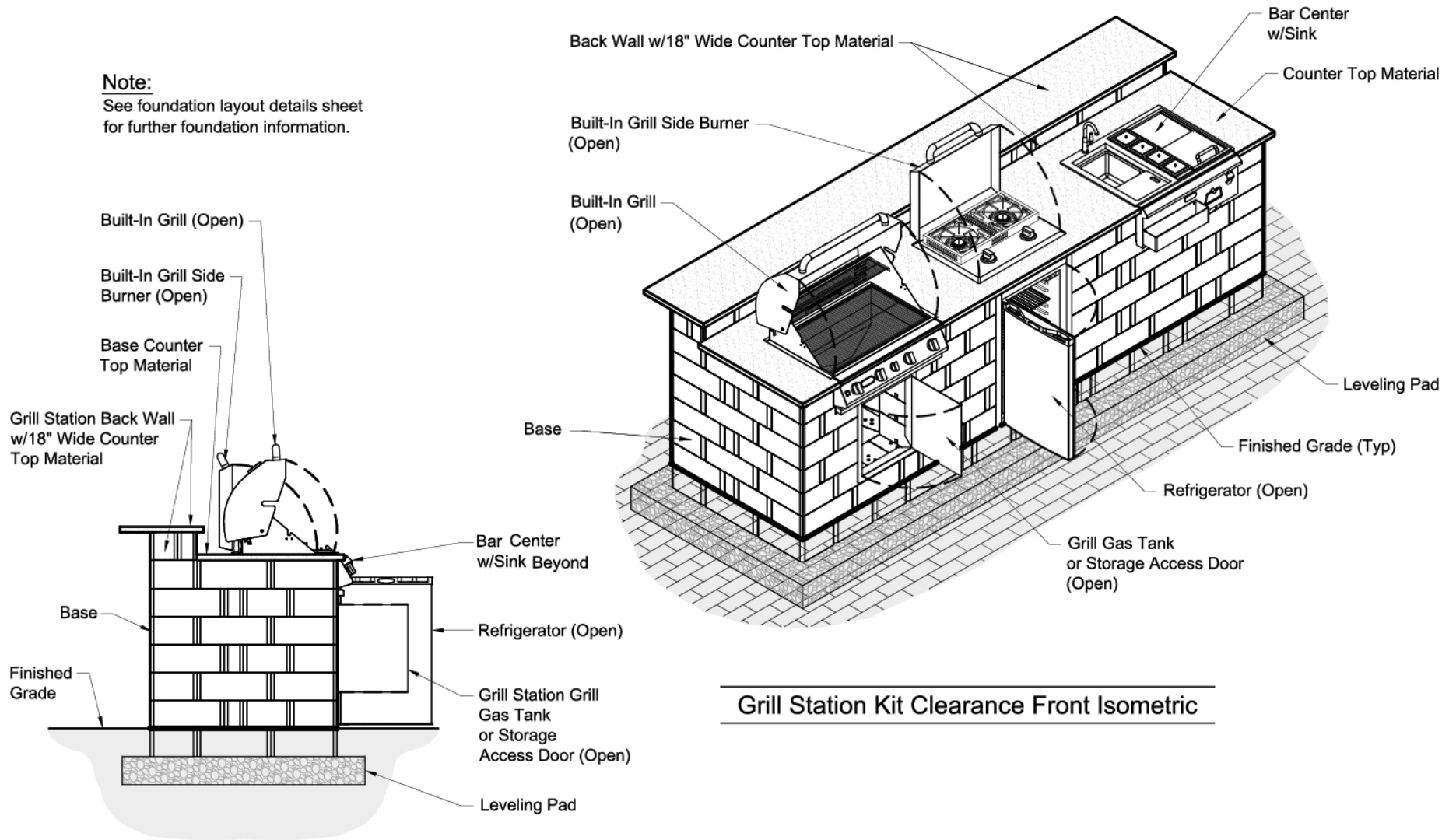

Grill Station Kit Clearance Side Elevation

Grill Station Kit Clearance Front Isometric

COURSE BY COURSE INSTRUCTIONS

Foundation Isometric

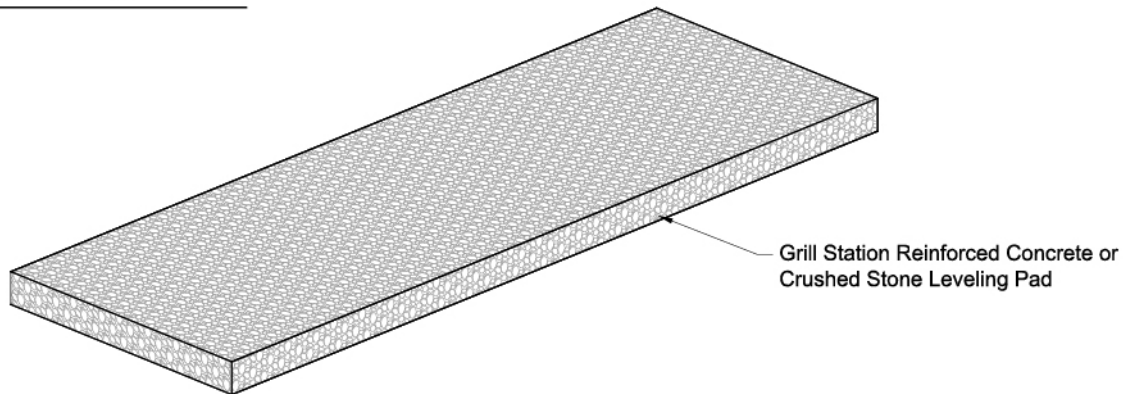

On Grade Installation Note:

If the Grill Station is to be built on top of a stable patio or hardscape surface eliminate the 1st course and base leveling pad for the grill station design.

Appliance Service Note:

Plan gas, electrical, water and drain service and install prior to and during construction as needed.

Foundation Plan

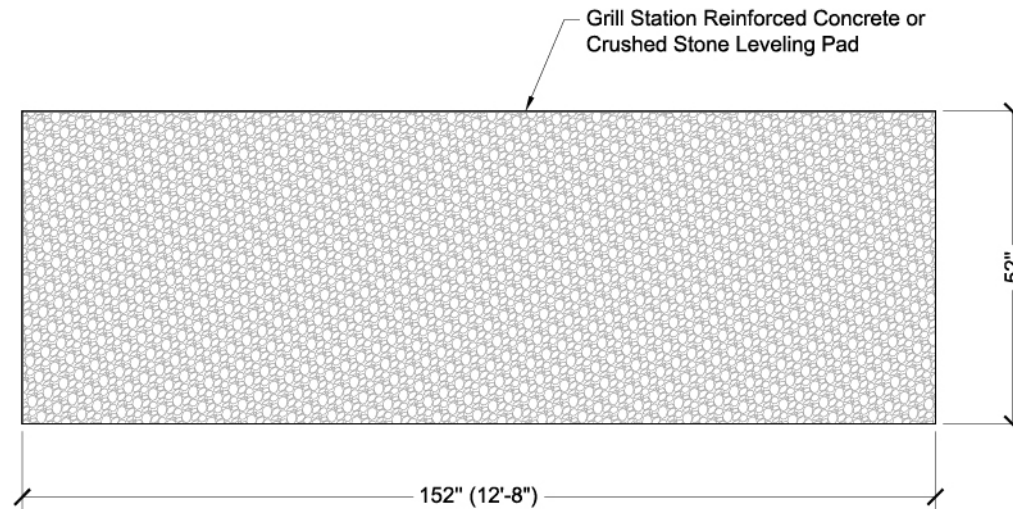

Remember to:

- Call 811 to locate utility lines prior to digging.
- Follow manufacturer's instructions and local codes.

COURSE BY COURSE INSTRUCTIONS

1st Course Isometric

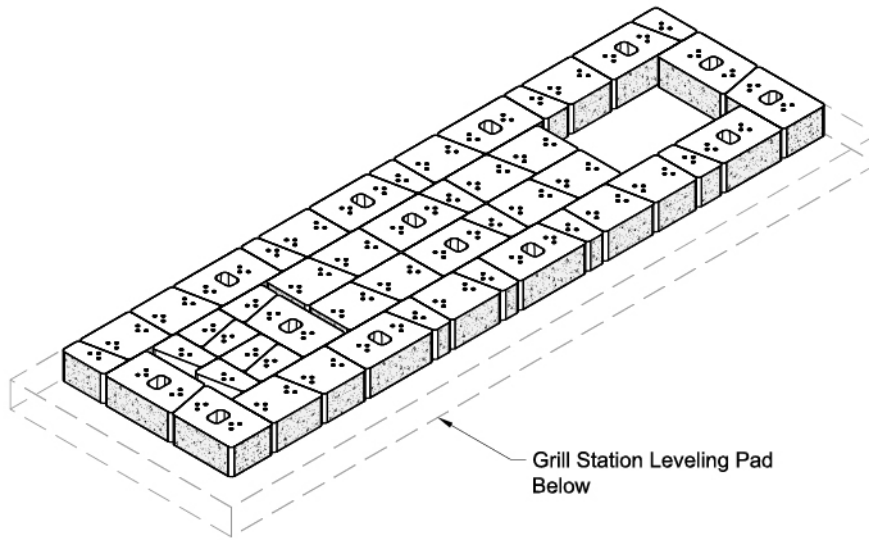

Grill Kit Width Note:

Due to block outside face texture variances when building the grill station kit courses the outside dimensions of the courses may get wider than desired. If required cut a interior perimeter unit to get the required outside dimension.

On Grade Installation Note:

If the Grill Station is to be built on top of a stable patio or hardscape surface eliminate the 1st course and base leveling pad for the grill station design.

1st Course Plan

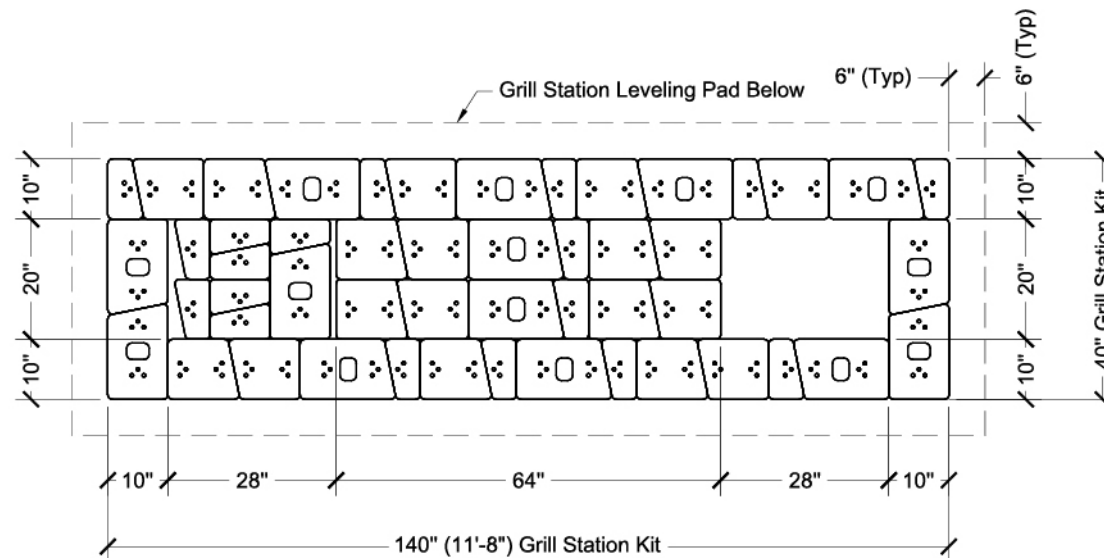

COURSE BY COURSE INSTRUCTIONS

2nd Course Isometric

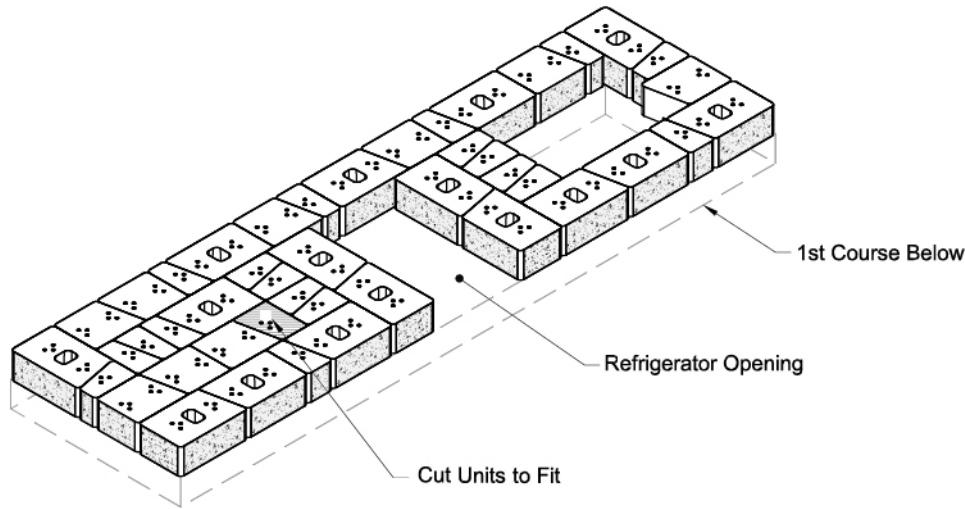

Block Cutting Note:

Using a concrete saw or wheel grinder tool w/masonry disk, cut block units as needed. Block units to be cut due to obstruction are labeled with solid hatching. Block units to be cut to fit are labeled with angular hatching.

2nd Course Plan

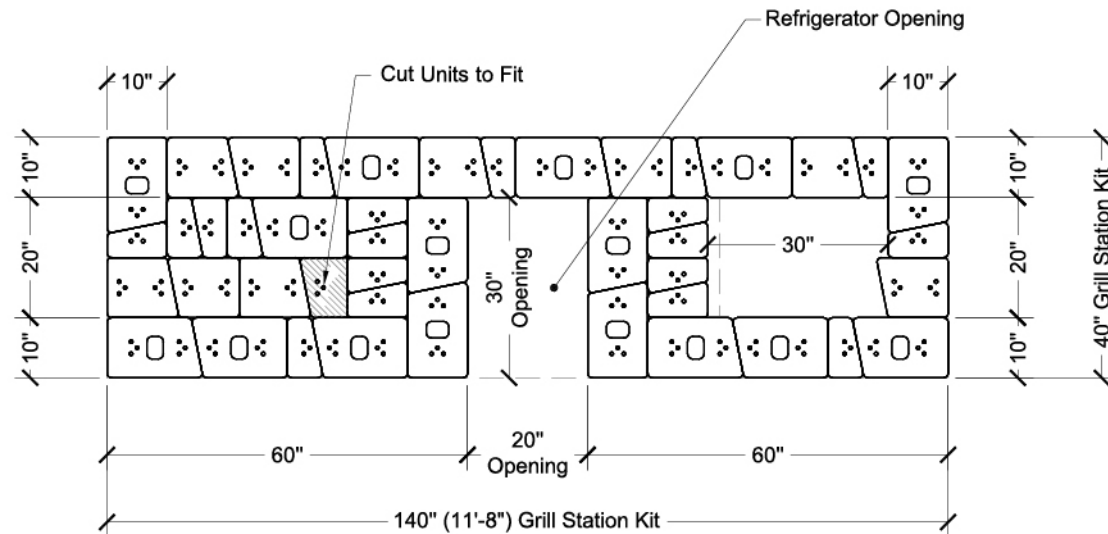

COURSE BY COURSE INSTRUCTIONS

3rd Course Isometric

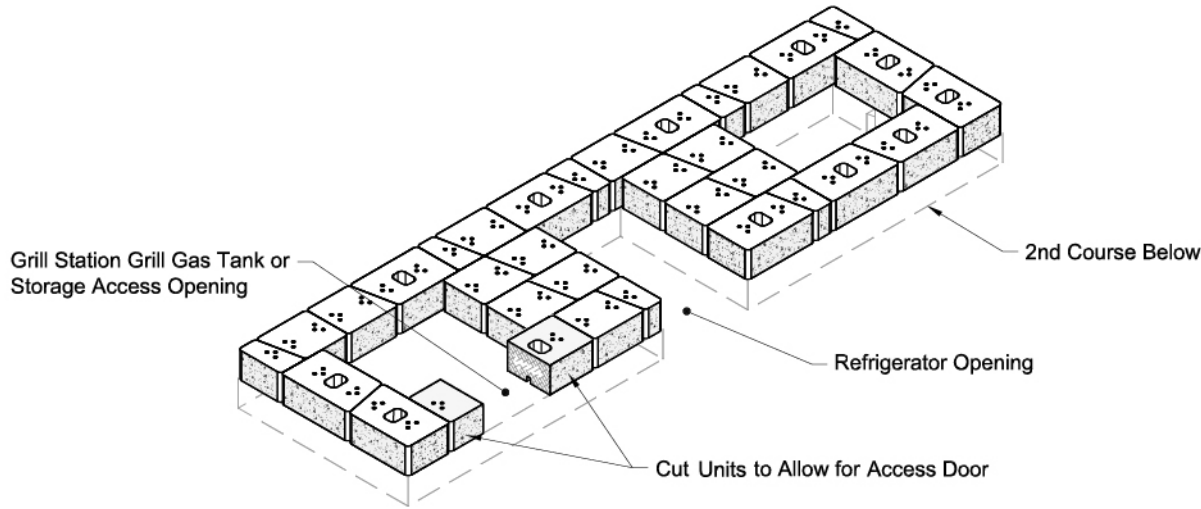

Block Cutting Note:

Using a concrete saw or wheel grinder tool w/masonry disk, cut block units as needed. Block units to be cut due to obstruction are labeled with solid hatching. Block units to be cut to fit are labeled with angular hatching.

Block Cutting for Appliances Note:

See appliance manufacturers installation instructions for correct block cutting to allow for proper fit for appliances.

3rd Course Plan

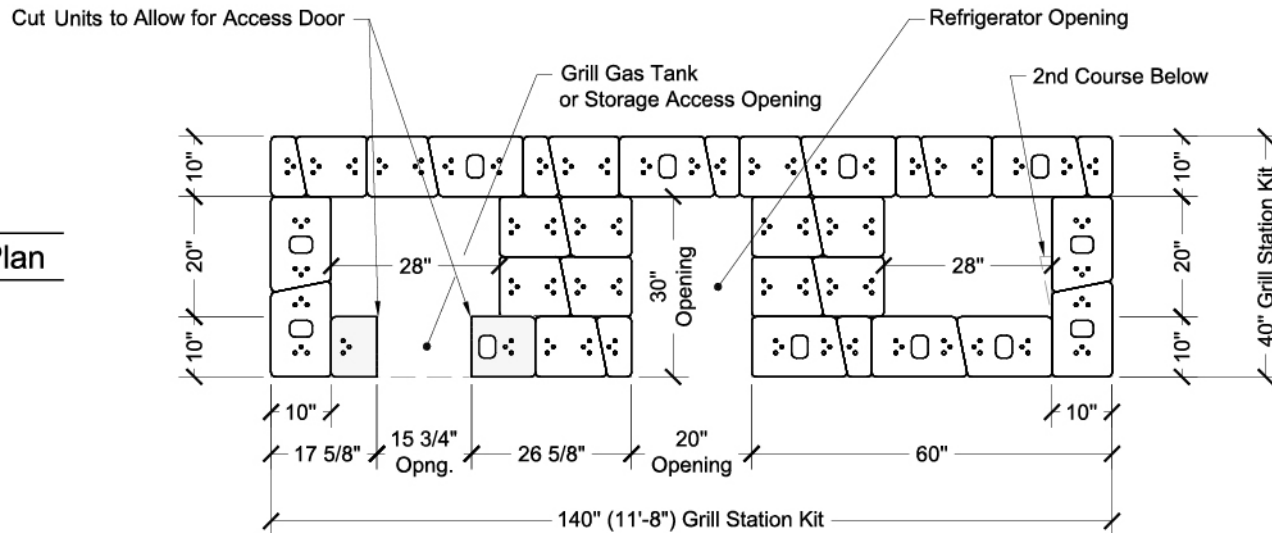

COURSE BY COURSE INSTRUCTIONS

4th Course Isometric

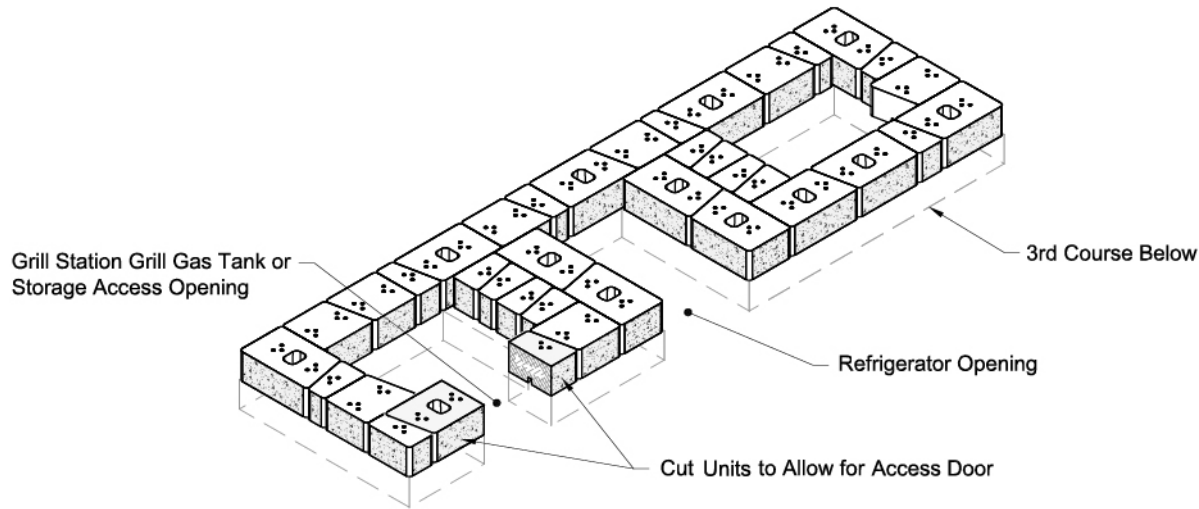

Block Cutting Note:

Using a concrete saw or wheel grinder tool w/masonry disk, cut block units as needed. Block units to be cut due to obstruction are labeled with solid hatching. Block units to be cut to fit are labeled with angular hatching.

Block Cutting for Appliances Note:

See appliance manufacturers installation instructions for correct block cutting to allow for proper fit for appliances.

4th Course Plan

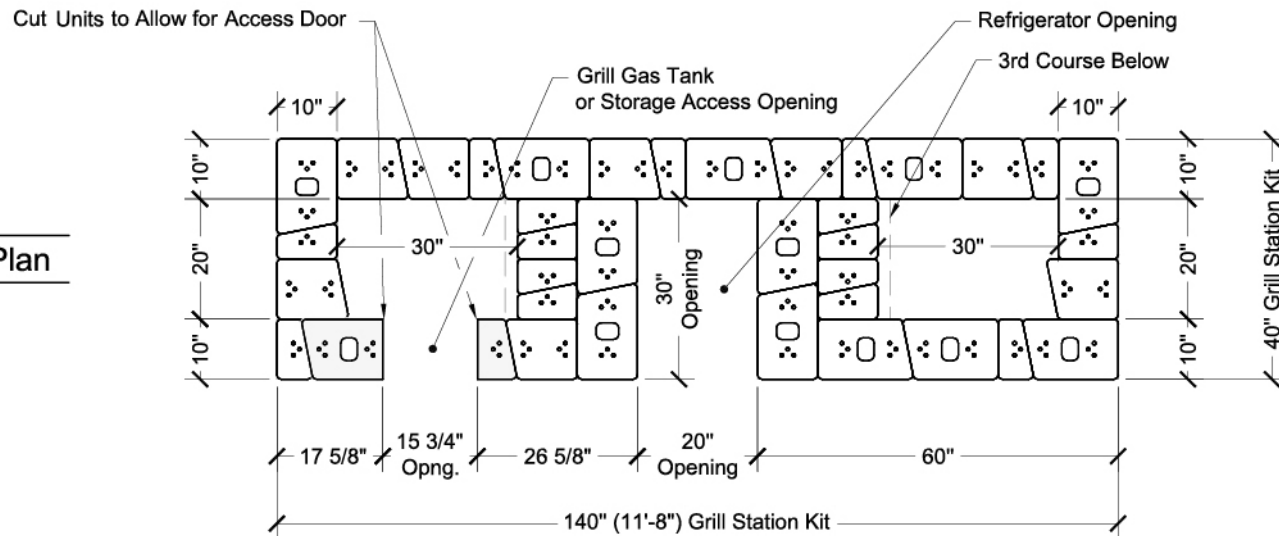

COURSE BY COURSE INSTRUCTIONS

5th Course Isometric

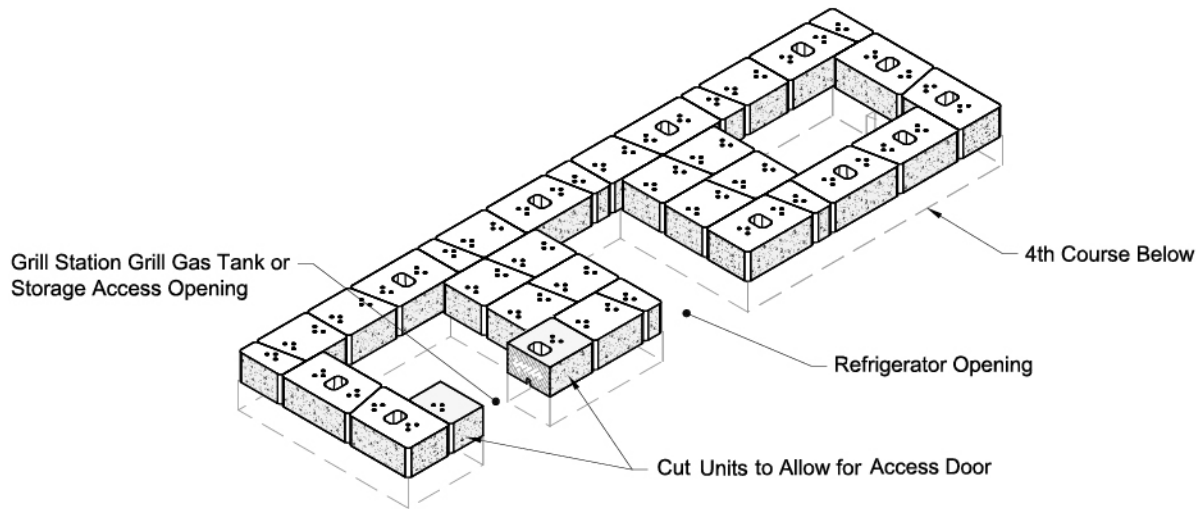

Block Cutting Note:

Using a concrete saw or wheel grinder tool w/masonry disk, cut block units as needed. Block units to be cut due to obstruction are labeled with solid hatching. Block units to be cut to fit are labeled with angular hatching.

Block Cutting for Appliances Note:

See appliance manufacturers installation instructions for correct block cutting to allow for proper fit for appliances.

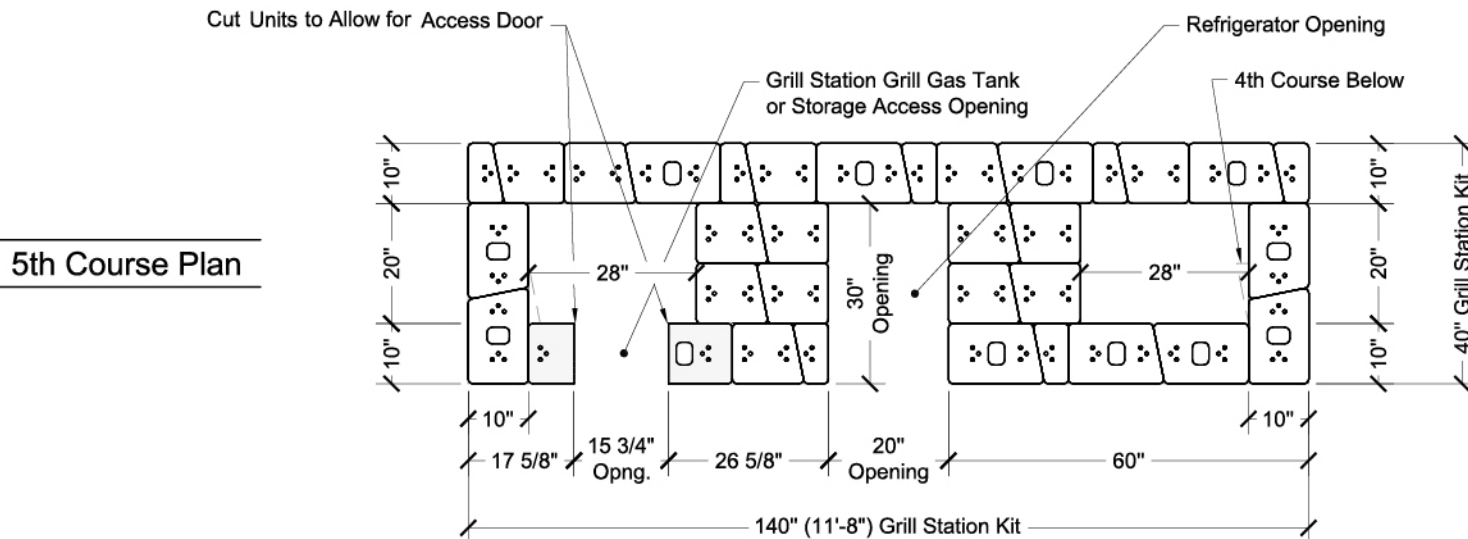

5th Course Plan

COURSE BY COURSE INSTRUCTIONS

6th Course Isometric

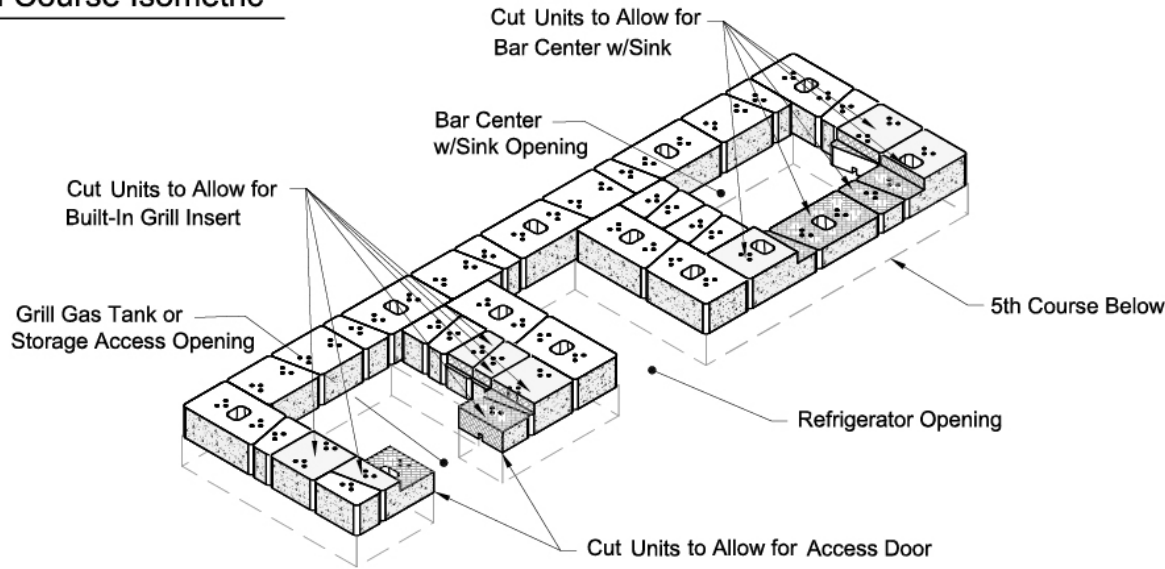

Block Cutting Note:

Using a concrete saw or wheel grinder tool w/masonry disk, cut block units as needed. Block units to be cut due to obstruction are labeled with solid hatching. Block units to be cut to fit are labeled with angular hatching.

Block Cutting for Appliances Note:

See appliance manufacturers installation instructions for correct block cutting to allow for proper fit for appliances.

6th Course Plan

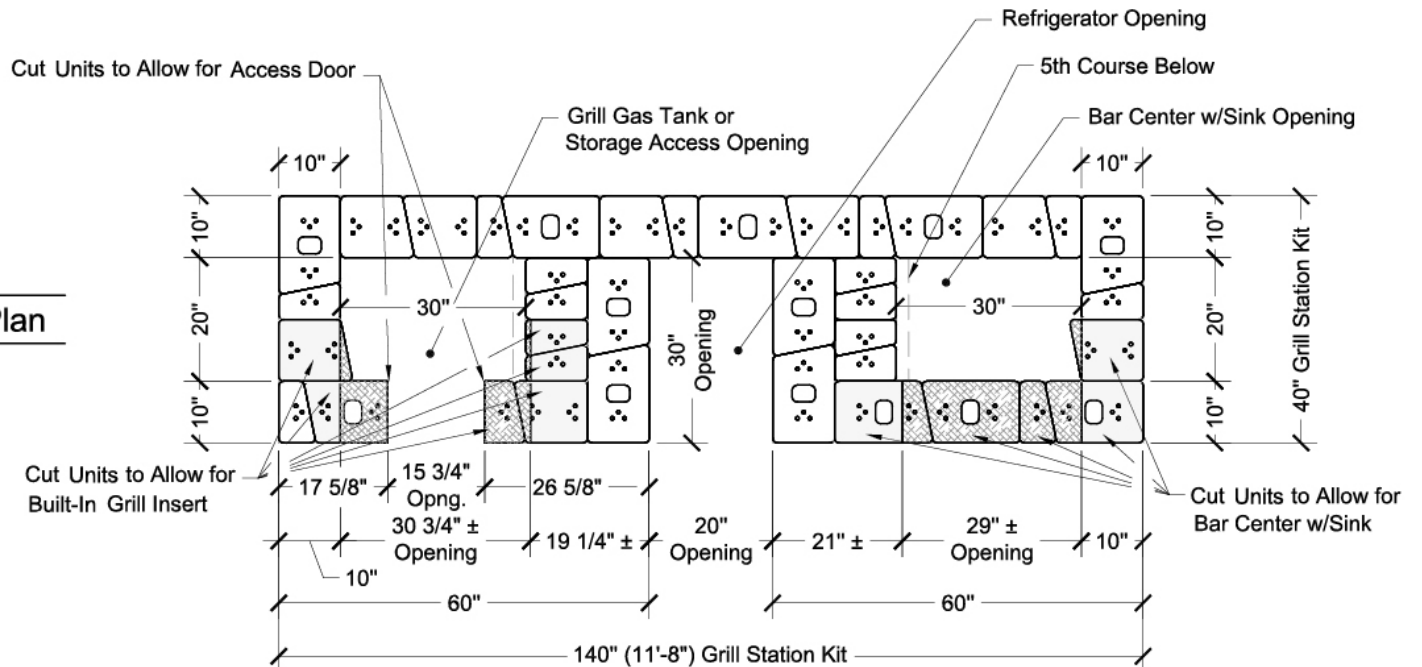

COURSE BY COURSE INSTRUCTIONS

7th Course Isometric

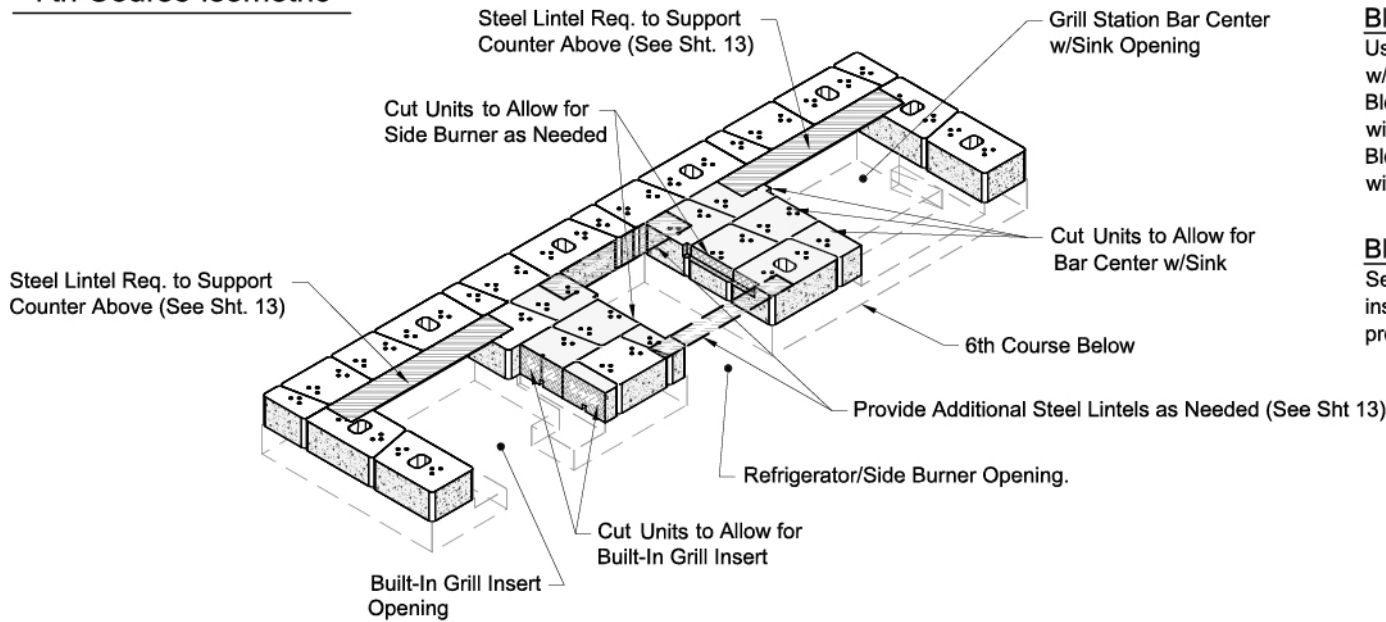

Block Cutting Note:

Using a concrete saw or wheel grinder tool w/masonry disk, cut block units as needed. Block units to be cut due to obstruction are labeled with solid hatching. Block units to be cut to fit are labeled with angular hatching.

Block Cutting for Appliances Note:

See appliance manufacturers installation instructions for correct block cutting to allow for proper fit for appliances.

7th Course Plan

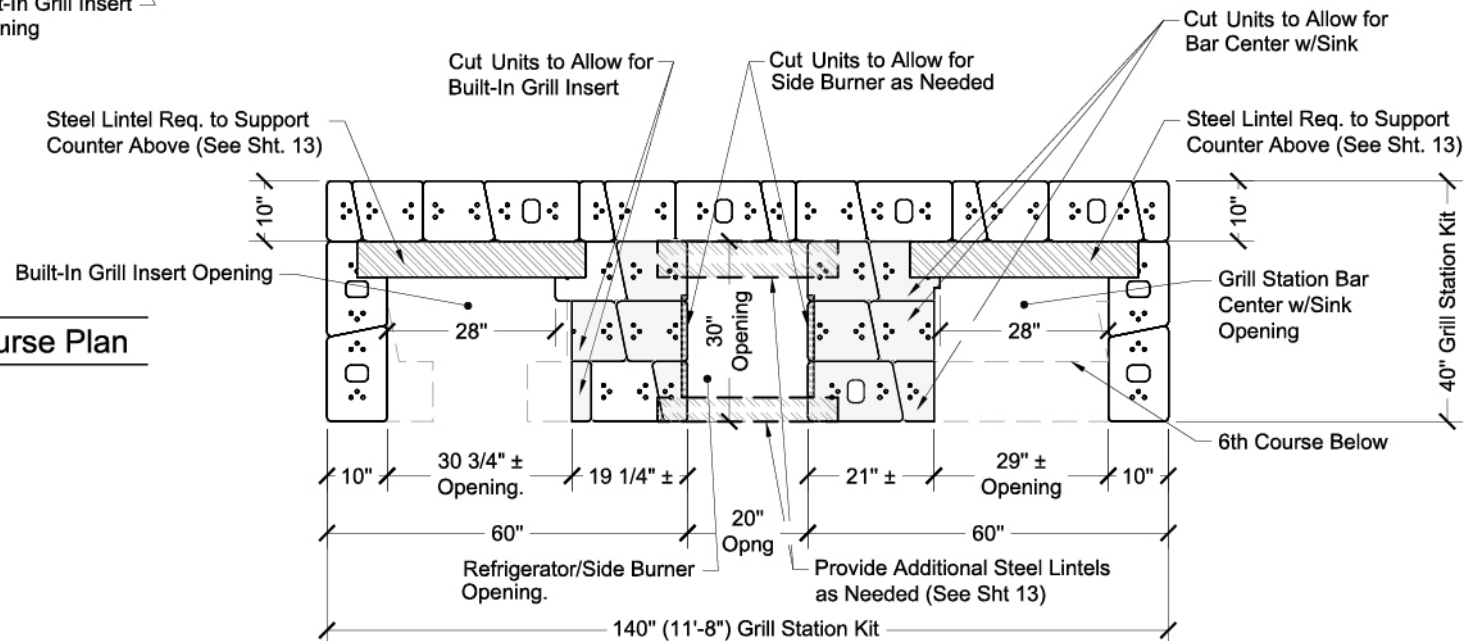

COURSE BY COURSE INSTRUCTIONS

7th Course Base Counter Top Support Isometric

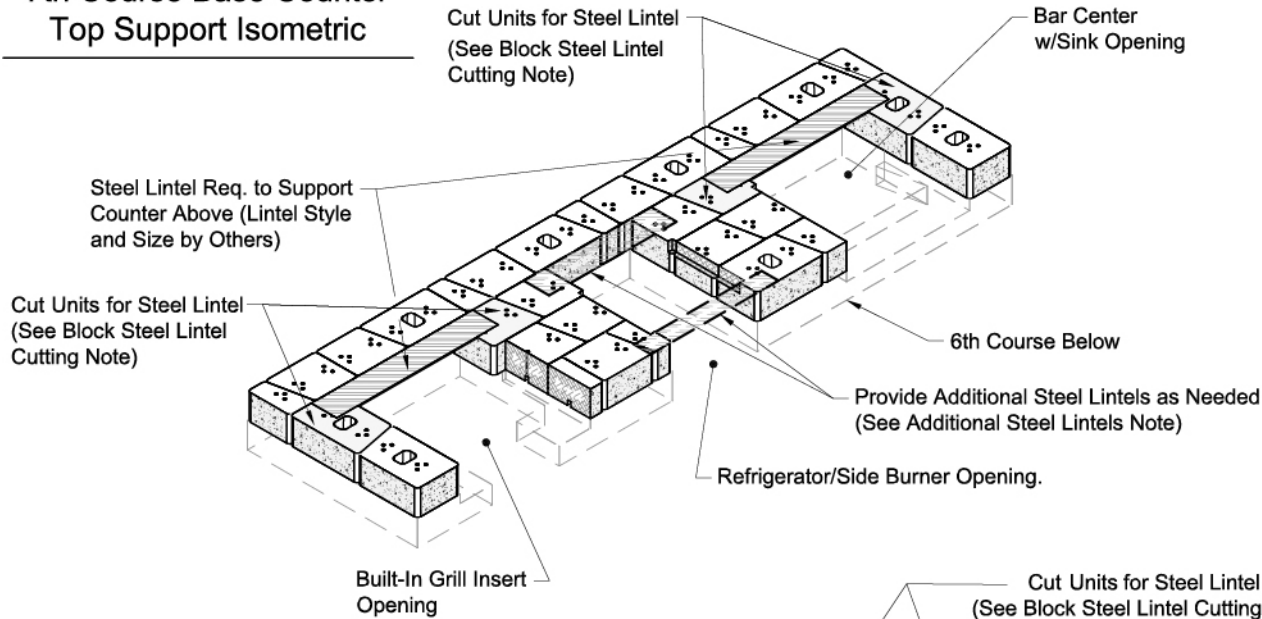

Additional Steel Lintels Note:

Provide additional steel lintel support above refrigerator opening, this course, for base counter top above as needed depending on counter top material used. Lintel style and size by others.

Block Steel Lintel Cutting Note:

Prior to installing steel lintel, use a wheel grinding tool to notch out top of block creating a level shelf to place steel lintel, such that lintel is flush with top of cut block. Block units to be cut for steel lintel are shown with solid hatching.

7th Course Base Counter Top Support Plan

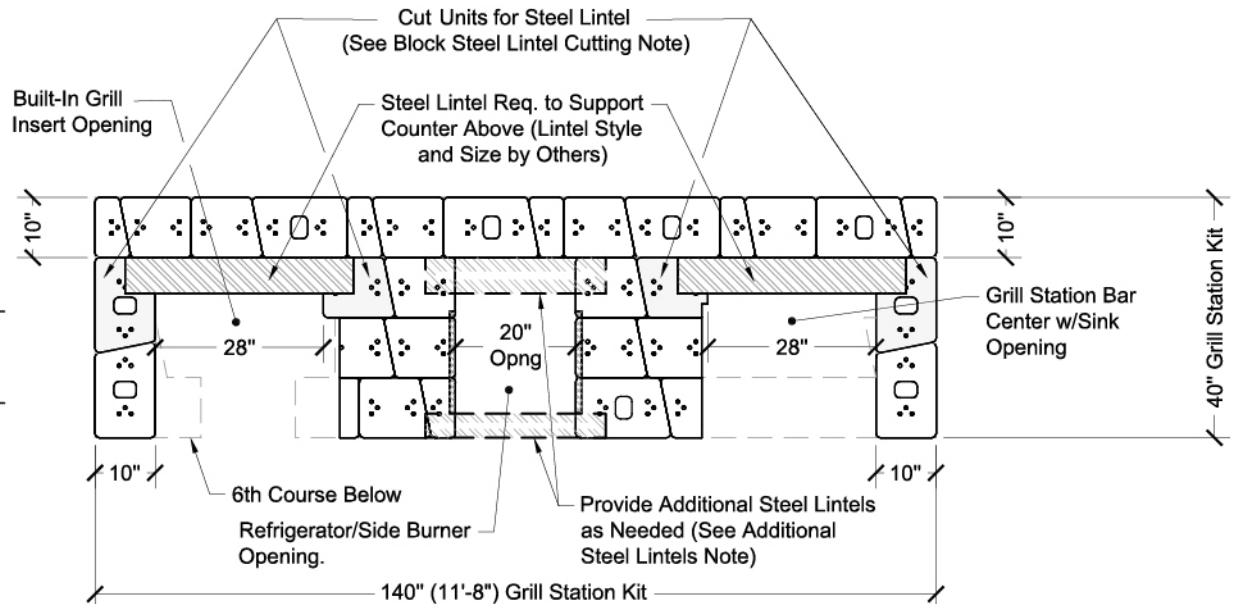

COURSE BY COURSE INSTRUCTIONS

7th Course Base Counter Top Isometric

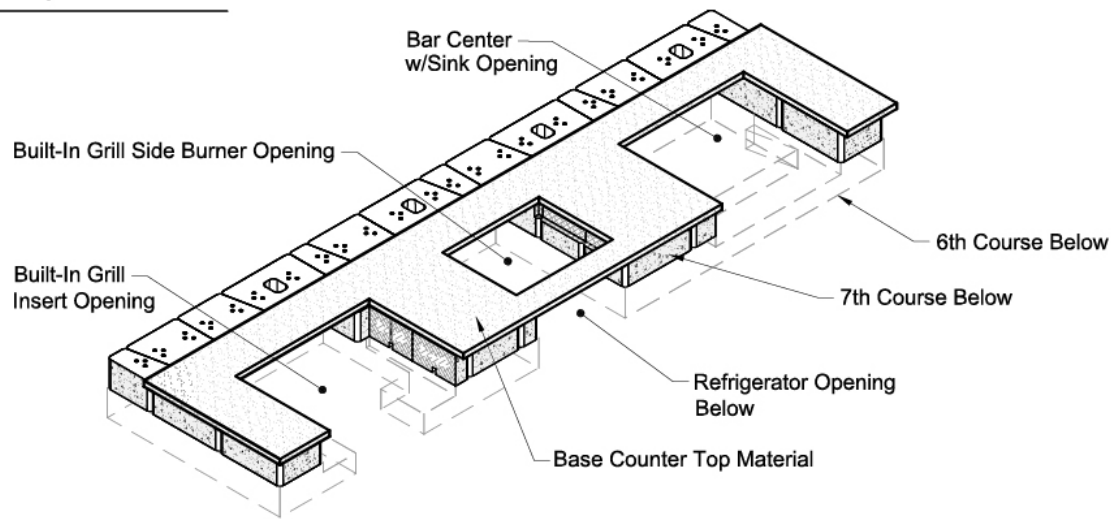

Counter Top Cutting for Appliances Note:

See appliance manufacturers installation instructions for correct counter top opening sizes. Cut to allow for proper fit for appliances. Unless otherwise directed, use a concrete saw or wheel grinder tool w/masonry disk to cut the counter top as needed.

Counter Top Installation Note:

Unless otherwise directed install and secure counter top material with adhesive as per manufacturers installation instructions.

7th Course Base Counter Top Plan

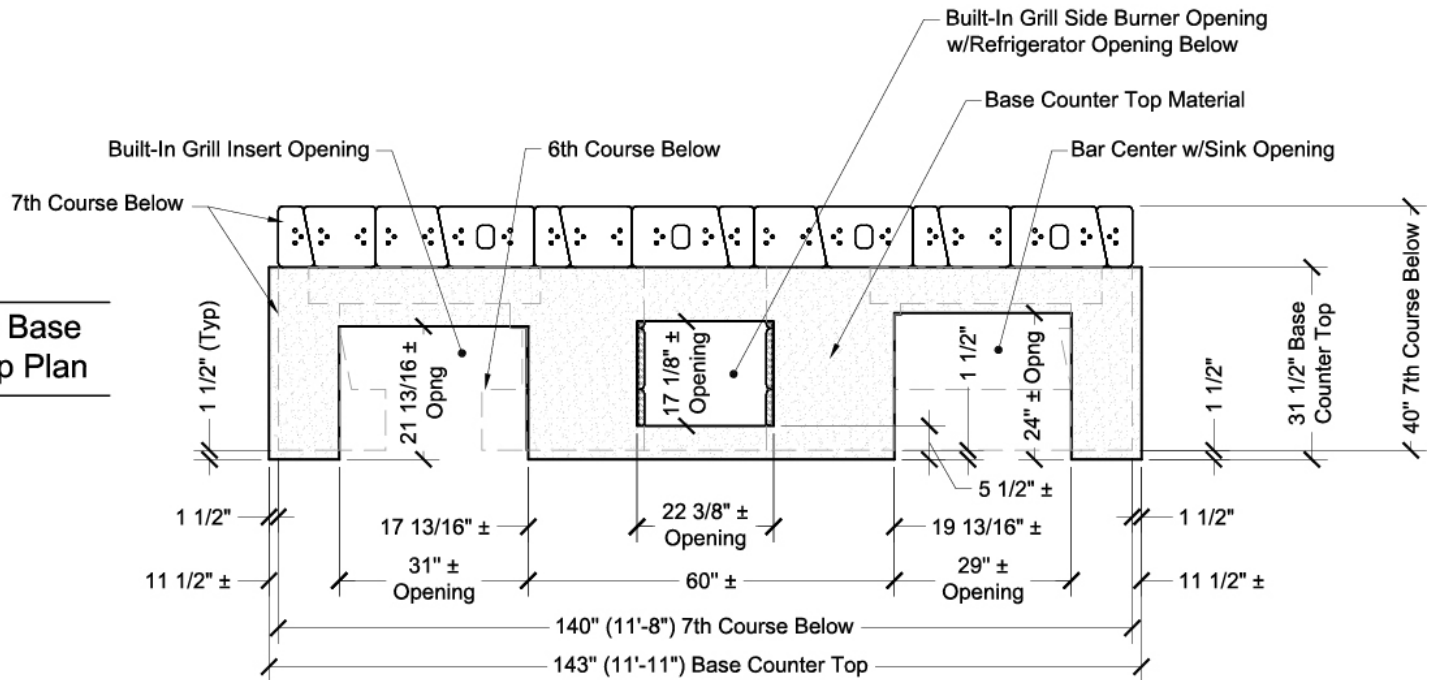

COURSE BY COURSE INSTRUCTIONS

8th Course Isometric

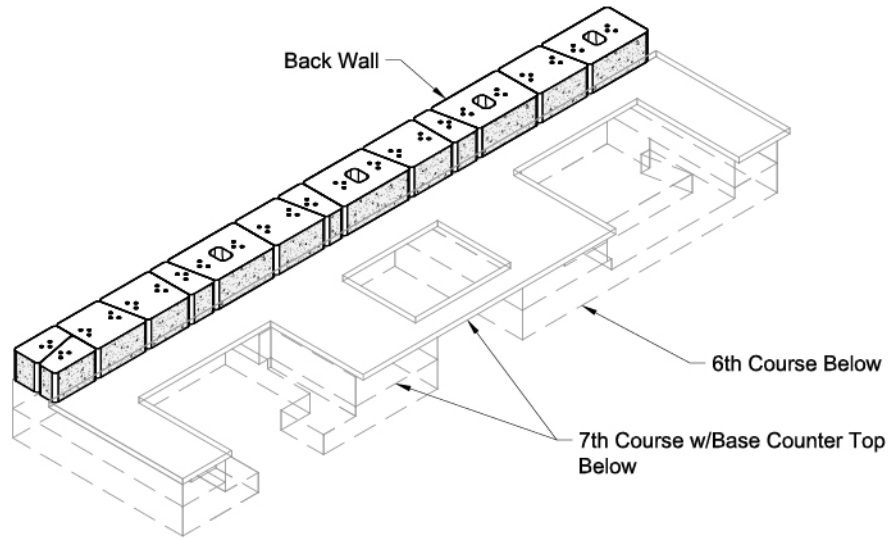

8th Course Plan

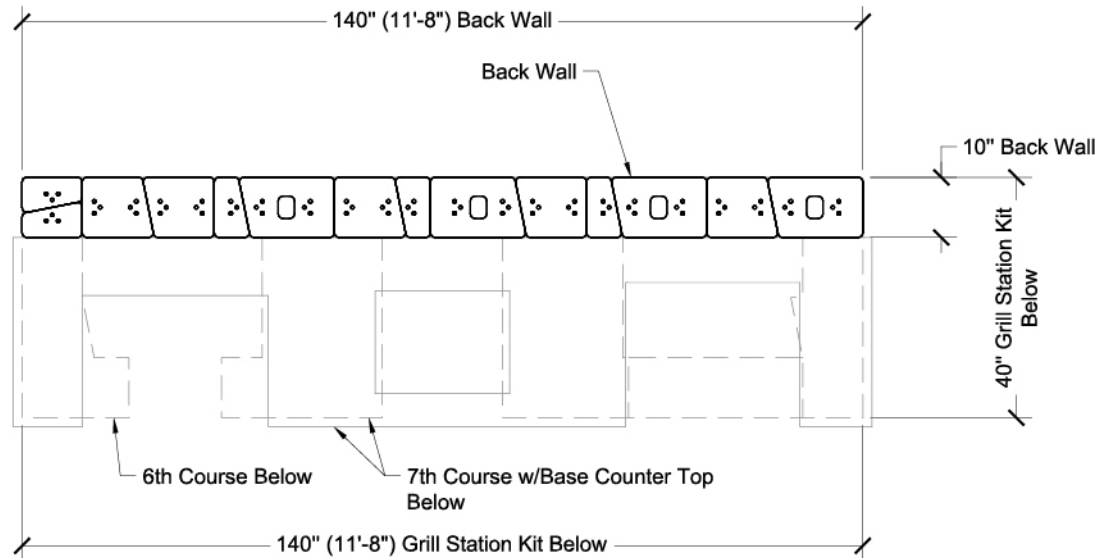

COURSE BY COURSE INSTRUCTIONS

8th Course Back Wall Counter Top Isometric

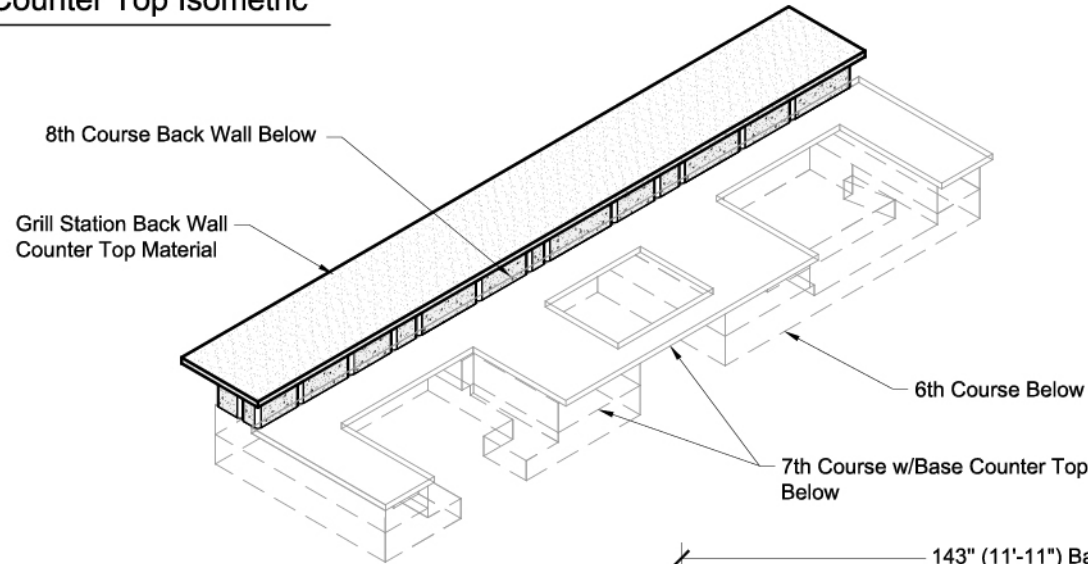

Counter Top Cutting Note:

Unless otherwise directed, use a concrete saw or wheel grinder tool w/masonry disk to cut the counter top as needed.

Counter Top Installation Note:

Unless otherwise directed install and secure counter top material with adhesive as per manufacturers installation instructions.

Counter Top Support Note:

Provide under counter support as needed depending on the over hang of the counter and the type of counter top material used.

8th Course Back Wall Counter Top Plan

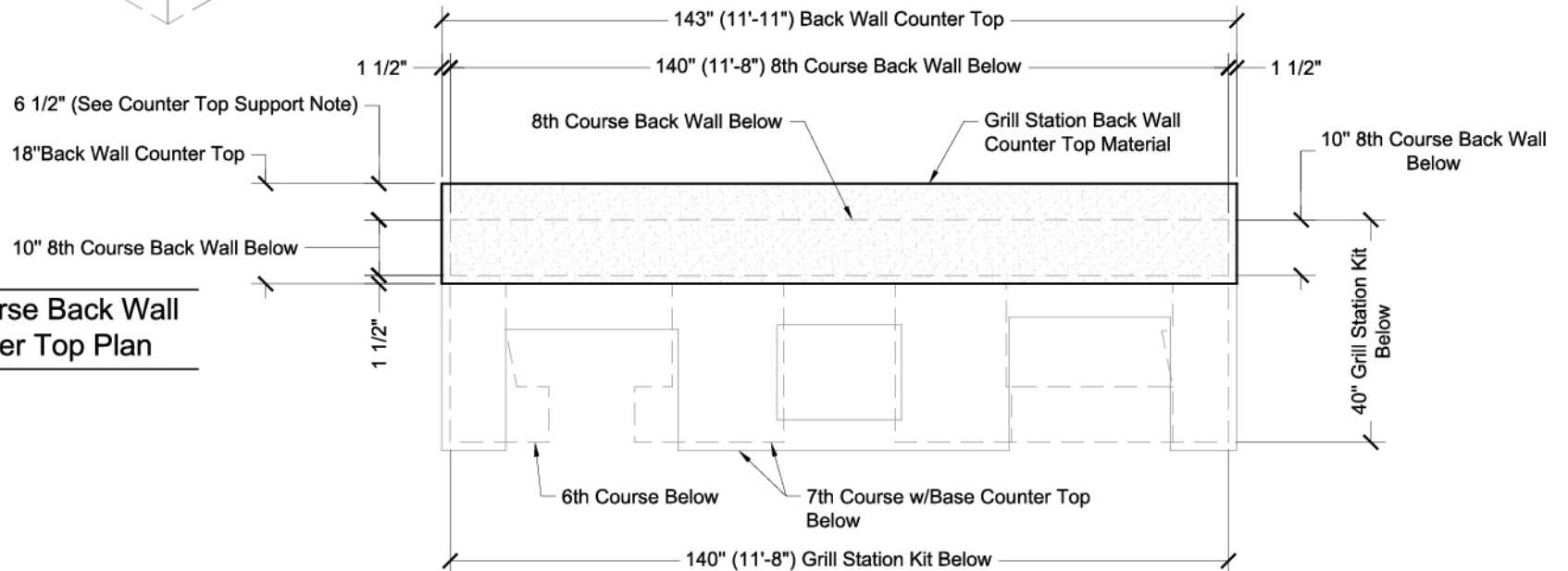

Don't forget to check out all of our Keystone Outdoor Living designs on keystonewalls.com.



Outdoor Kitchen Designs



Fireplaces



Columns



Fire Pits



Water Feature



Bench



Keystone Retaining Wall Systems LLC
4444 West 78th Street • Minneapolis, MN 55435
(800) 747-8971 • www.keystonewalls.com

FOLLOW US



We reserve the right to improve our products and make changes in the specifications and design without notice. The information contained herein has been compiled by KEYSTONE and to the best of our knowledge, accurately represents the KEYSTONE product use in the applications which are illustrated. Final determination of the suitability for the use contemplated and its manner of use are the sole responsibility of the user.