

Strength, Set In Steel

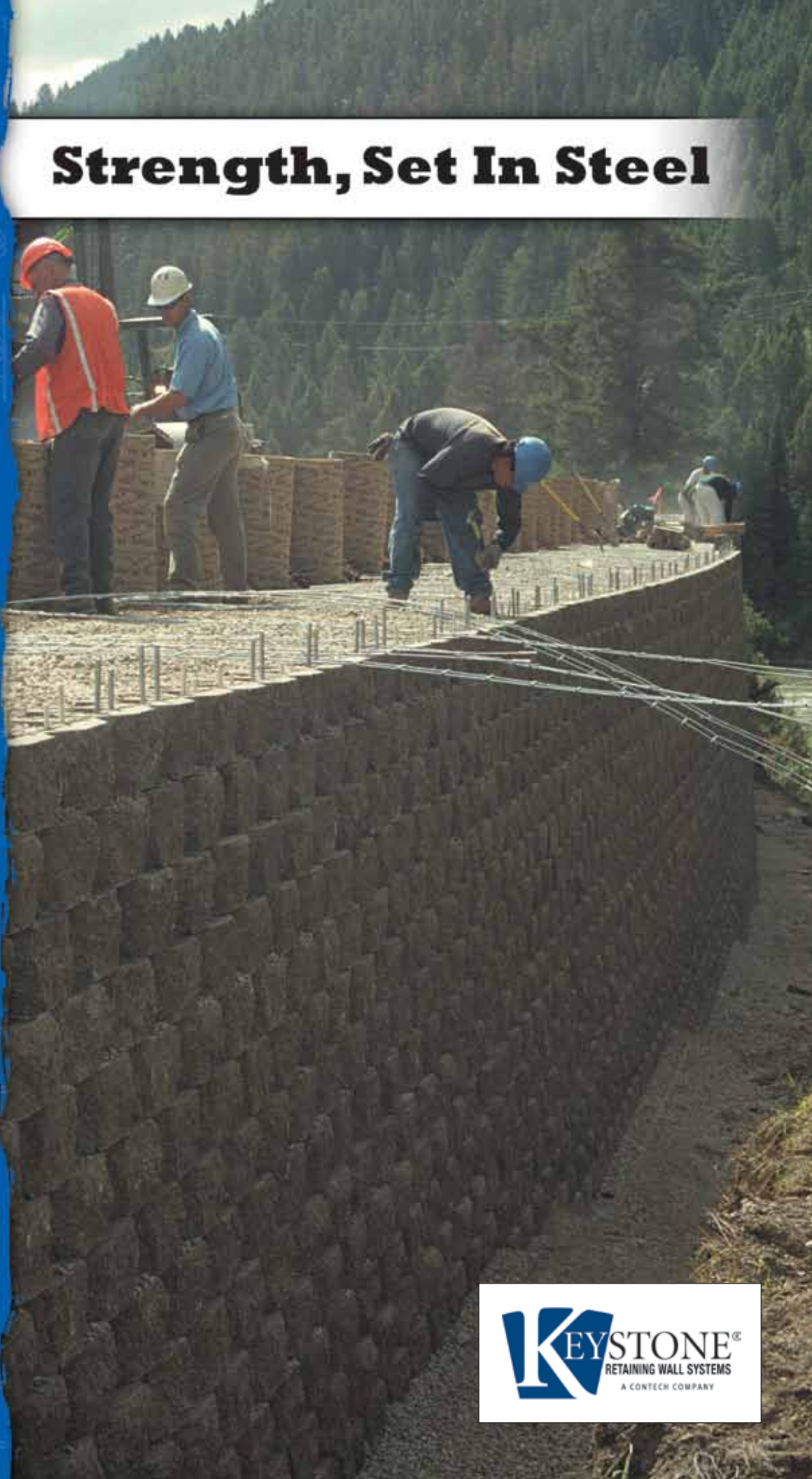

KEYSTEEL

SQ. FT. PANEL SYSTEM

SQFT
KEYSTEEL

PANEL SYSTEM
BY CONTECH

KEYSTONE[®]
RETAINING WALL SYSTEMS
A CONTECH COMPANY



Keystone KeySteel Sq. Ft. Panel System is a world-class structural retaining wall system, specifically designed for use with highways and heavy construction. KeySteel combines patented Keystone modular concrete units and inextensible steel soil reinforcement to develop an extremely stable, aesthetically appealing and cost-effective retaining wall structure.

Keystone KeySteel's aesthetic options include a wide range of completed wall appearances without the high cost of customization. KeySteel also utilizes design methodology and material components that comply with the standards for inextensible reinforcement as outlined in the current AASHTO Standard Specifications for Highway Bridges.



Galvanized Steel Connection Pins
 9/16" x 8"
 (14.3 x 203 mm)



Fiberglass Alignment Pins
 1/2" x 5-1/4"
 (12.7 x 133mm)

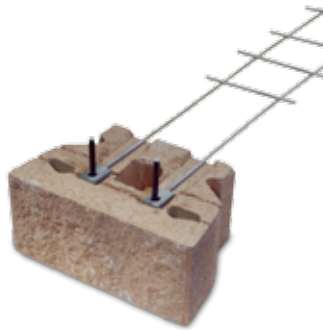

Straightface

8"h x 18"w x 12"d
 (203 x 457 x 305 mm)



Sculptured Rock Face

8"h x 18"w x 12"d
 (203 x 457 x 305 mm)



Features & Benefits

Durable Components

- *Inextensible steel reinforcement and 75 to 100 years of design life*

Aesthetic Appeal

- *Wide variety of color options, textures and patterns*

Design Flexibility

- *Curves, corners and unique geometries*

Ease of Construction

- *Quick and easy, no cranes required*

Cost-Effective Results

- *Competitive with other MSE structures*

Intended for the Most Demanding Jobs

- *Deflections with steel reinforcement are reduced by over 66% compared to geosynthetic reinforcement*

Ideal for Deflection Sensitive Applications:

- *Bridge abutments*
- *Tall walls*
- *Walls with heavy surcharges*
- *Walls where loads or structures bear on or are immediately behind the reinforced mass*



- *Designed in accordance with more rigorous AASHTO standards.*
- *Designed for transportation or other projects requiring AASHTO compliance.*
- *KeySteel is a high-performance, mechanically-stabilized earth retaining wall system for highway and heavy applications using inextensible reinforcing. KeySteel is evaluated by HITEC, in accordance with AASHTO specifications.*

KeySteel modular components interlock in a running bond pattern, utilizing fiberglass alignment pins and galvanized steel connection pins.

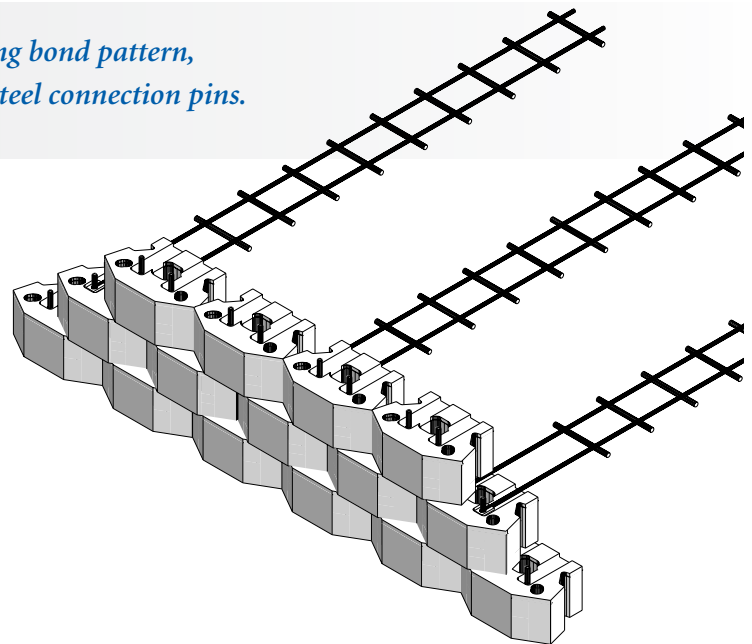
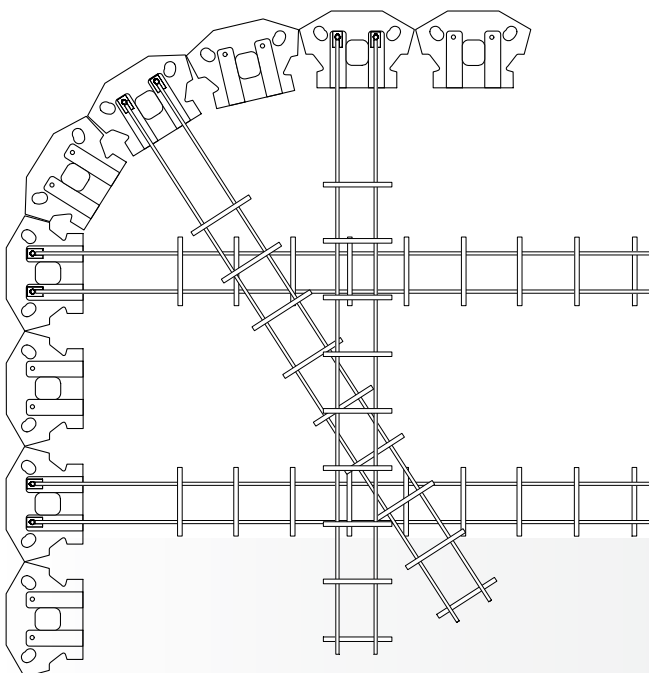

A typical steel layout plan for curves and straight wall construction.

Strength

The strength and performance of a retaining wall system is an obvious top consideration for wall specifiers and designers. KeySteel is one of the most durable retention solutions available. It features patented concrete units that are manufactured to a minimum compressive strength of 4,000 psi. The units are dry stacked and interlocked vertically and horizontally using high-strength fiberglass pins and galvanized steel pins. This method provides a very strong, mechanically interlocked facing system.

KeySteel is also the ideal product for tall walls. Many walls using KeySteel have been constructed to over 50 ft. (15 m) with a variety of loading conditions. KeySteel steel soil reinforcement offers an economical and extremely strong structural solution for tall walls and extreme loading conditions.

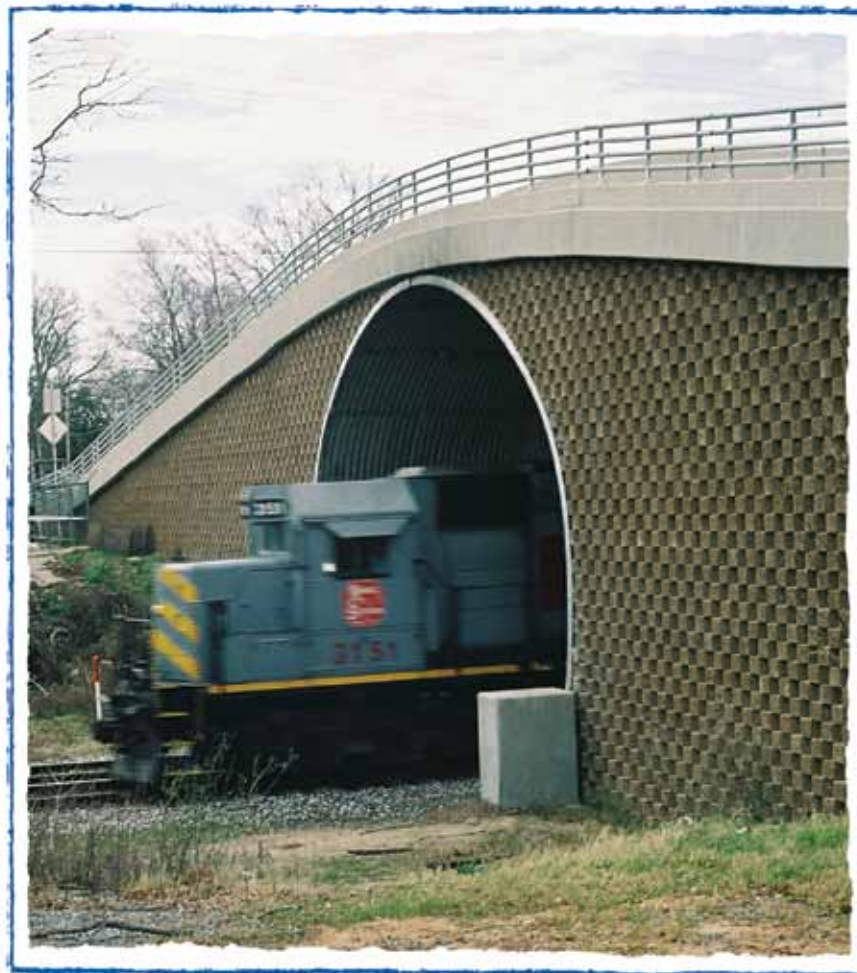

KeySteel Flexibility Offers Seismic & Aesthetic Benefits

Copings, crash barriers, railing options, construction slip joints, curves and corners are all possible design elements in the KeySteel package, without the need for specialized moldings and custom fabrication.

Seismic design loads are easily factored into the KeySteel design analysis. The semi-flexible (MSE) system handles seismic events better than more rigid systems.

KeySteel structures have a proven track record of high performance, withstanding seismic events in the Pacific Rim and Western United States without failure or significant detrimental effects on the wall structure.

KeySteel Construction Sequence

STEP 1

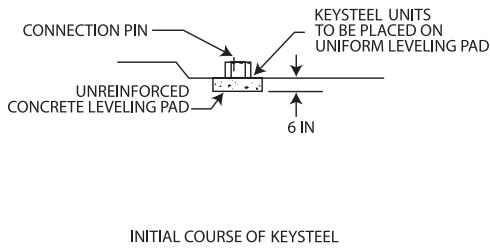

STEP 2

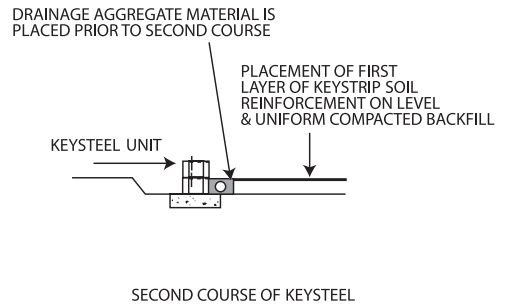

STEP 3

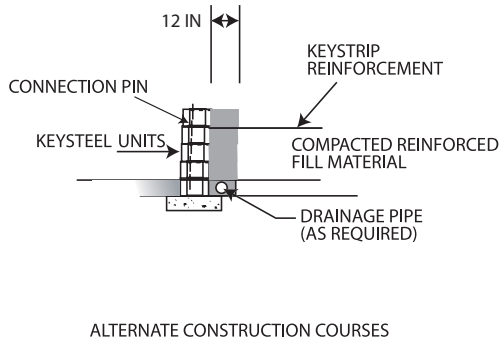

STEP 4

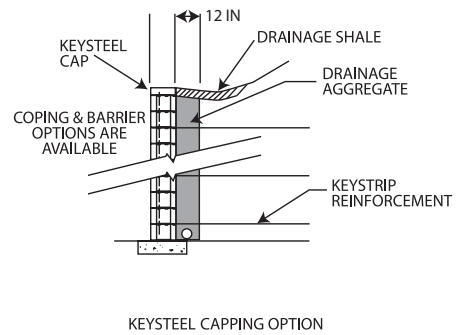

GUARDRAIL

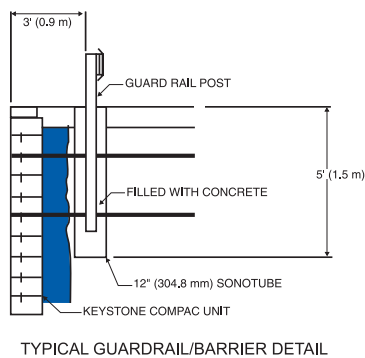

90° CORNER

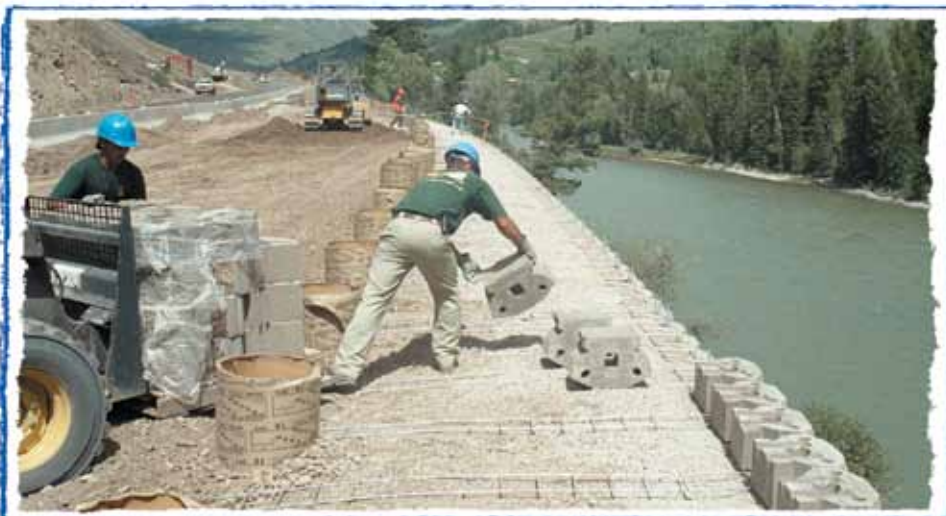

KeySteel installation is rapid and minimizes heavy equipment requirements.

KeySteel is also cost-competitive with all forms of AASHTO specified MSE structures.



A Strong, Structural Solution

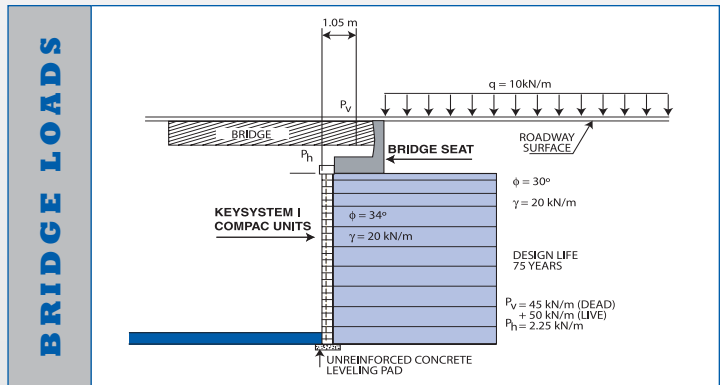
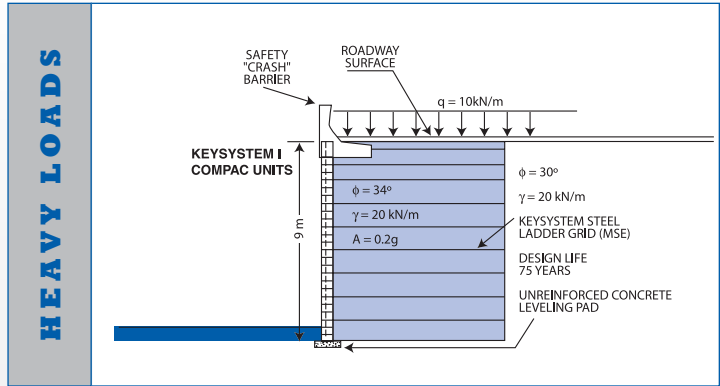

KeySteel handles all structures with heavy loads and crash barriers and also supports bridge loads and approach walls.

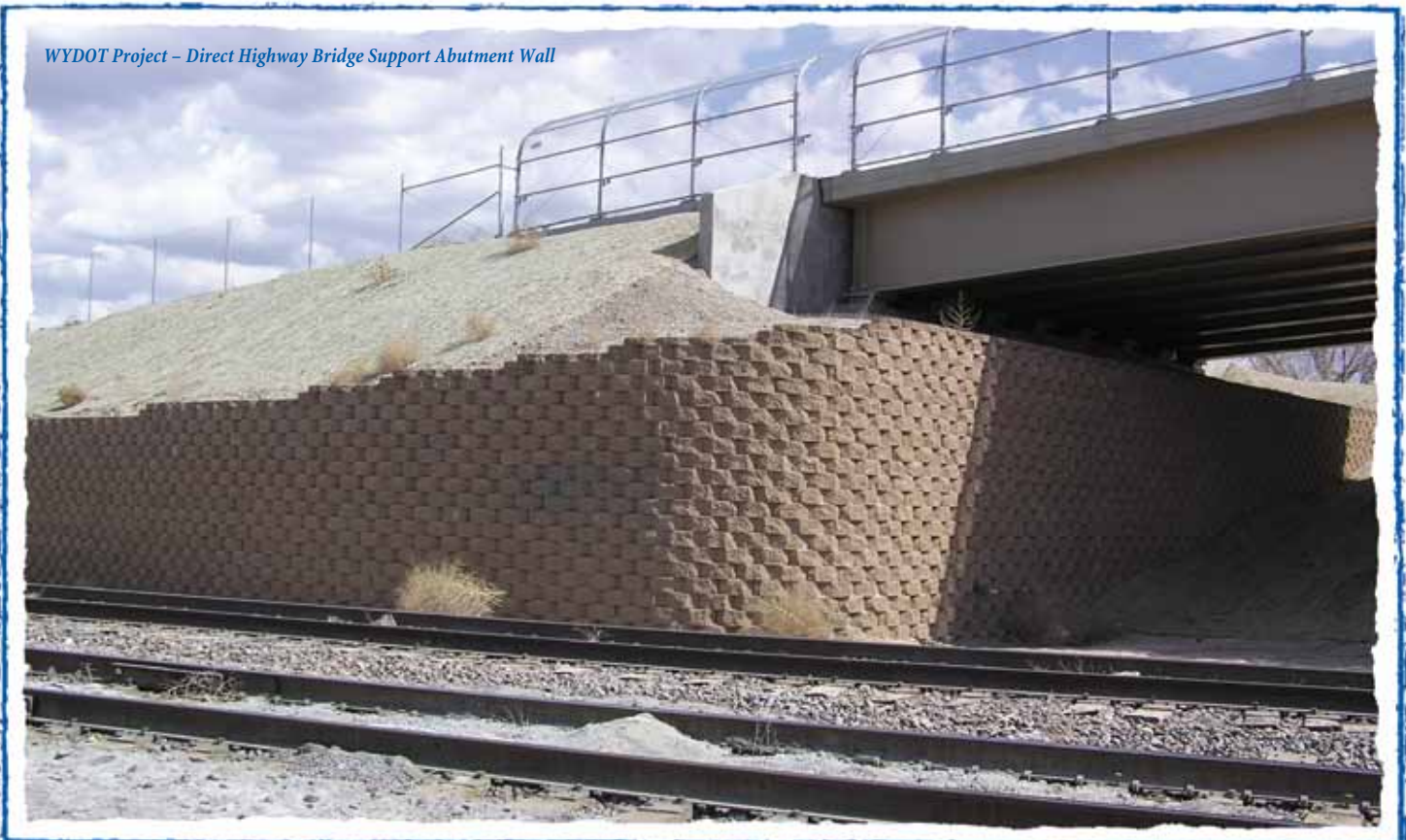

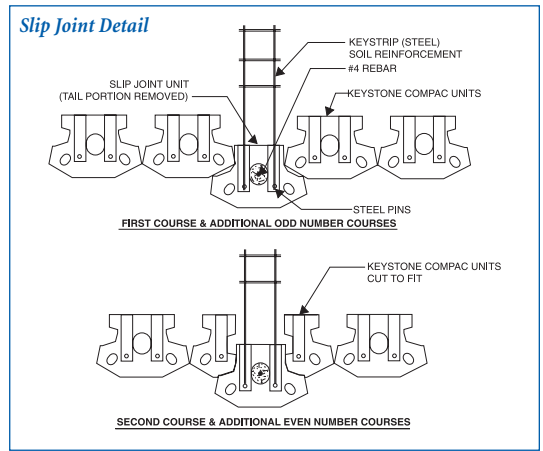

The Keystone Advantage

When KeySteel is specified, a complete retaining wall system is engineered and supplied to meet site-specific conditions. They also ensure timely arrival and sequencing of materials for construction.

After over 20 years at the forefront of the industry, Keystone Retaining Wall Systems, Inc. continues to set the standard for excellence and innovation within the segmental retaining wall industry. Keystone represents the global benchmark in soil retention, erosion control and landscape systems. Holding over 50 patents, Keystone symbolizes cutting-edge design, performance and aesthetics. Keystone partners with the best network of product developers, engineers, sales professionals and manufacturers in the business. They help ensure that Keystone offers the best in site solutions for residential, commercial, recreational, industrial and government applications.





Distributed by:



Keystone is a subsidiary of



Keystone Retaining Wall Systems, Inc. reserves the right to improve its products and make changes to its specification and design without notice. The information contained herein has been compiled by Keystone and to the best of its knowledge, accurately represents the Keystone product and how it may be used in the applications which are illustrated. Site conditions, including load pressures acting on the wall, soil types and drainage conditions, may vary. Final determination of the suitability of the product for the use contemplated and the manner of product use are the sole responsibility of the user. Good construction practices and local building codes require the use of an engineered design when constructing retaining walls or free-standing walls in many conditions. Structural design and analysis should be provided by a qualified engineer.

©2007 Keystone Retaining Wall Systems, Inc. • A CONTECH Company • 4444 West 78th Street, Minneapolis, Minnesota 55435 • (800) 747-8971 • fax (952) 897-3858 • M-0001-S

w w w . k e y s t o n e w a l l s . c o m